



## Quasar 900

### Open Path Gas Detection System

## User Guide



6021 Innovation Blvd, Shakopee, MN 55379 , USA  
Phone: +1 (973) 239 8398 Fax: +1 (973) 239 7614  
Website: [www.spectrex.net](http://www.spectrex.net) Email: [spectrex@spectrex.net](mailto:spectrex@spectrex.net)



## **Legal Notice**

The SPECTREX SafEye system described in this document is the property of Rosemount.

No part of the hardware, software or documentation may be reproduced, transmitted, transcribed, stored in a retrieval system, or translated into any language or computer language, in any form or by any means, without prior written permission of Rosemount.

While great efforts have been made to assure the accuracy and clarity of this document, Rosemount assumes no liability resulting from any omissions in this document, or from misuse of the information obtained herein. The information in this document has been carefully checked and is believed to be entirely reliable with all of the necessary information included. Rosemount reserves the right to make changes to any products described herein to improve reliability, function, or design, and reserves the right to revise this document and make changes from time to time in content hereof with no obligation to notify any persons of revisions or changes. Rosemount does not assume any liability arising out of the application or any use of any product or circuit described herein; neither does it convey license under its patent rights or the rights of others.

TM888200 Rev. (An), February 2020



# Table of Contents

<b>Table of Contents .....</b>	<b>v</b>
<b>List of Figures .....</b>	<b>ix</b>
<b>List of Tables.....</b>	<b>ix</b>
<b>1 About this Guide .....</b>	<b>11</b>
1.1 Release History.....	12
1.2 Glossary and Abbreviations .....	12
1.3 Notifications .....	13
<b>2 Product Overview .....</b>	<b>15</b>
<b>3 Technical Description .....</b>	<b>17</b>
3.1 Features .....	17
3.2 Applications.....	18
3.3 Principles of Operation .....	18
3.3.1 Definitions of Terms .....	18
3.3.2 Spectral Fingerprint.....	19
3.3.3 Optical Path .....	19
3.3.4 Microprocessor Based .....	19
3.3.5 Gas Sensitivity .....	19
3.3.6 Gas Calibration .....	19
3.3.7 Flash Source .....	20
3.3.8 Heated Optics.....	20
3.3.9 HART Protocol .....	20
3.3.10 Modbus RS-485 .....	20
3.3.11 Tilt Mount .....	21
3.4 Product Certification .....	21
3.4.1 ATEX, IECEx.....	21
3.4.2 FM/FMC .....	21
3.4.3 SIL-2.....	21
3.4.4 Functional Test .....	22
3.4.5 TR CU/EAC.....	22
3.4.6 Inmetro (UL).....	22
3.5 Models and Types .....	22
3.6 Description.....	23
3.6.1 Flash Source Unit.....	24

3.6.2	Detector Unit.....	24
<b>4</b>	<b>Operating Modes.....</b>	<b>27</b>
4.1	Operational Modes .....	27
4.1.1	Normal Mode.....	27
4.1.2	Maintenance Call Mode (3mA Output).....	27
4.1.3	Fault Mode .....	27
4.1.4	Zero Calibration Mode (1mA Output) .....	28
4.2	Visual Indicators .....	28
4.3	Output Signals.....	29
4.3.1	0–20mA Current Output .....	29
4.3.2	RS-485 Interface .....	29
4.4	System Setup.....	30
4.4.1	Detection Function Programming .....	30
4.4.2	Detection Setup Function .....	30
4.4.3	Detector Default Setup .....	31
<b>5</b>	<b>Technical Specifications.....</b>	<b>33</b>
5.1	General Specifications .....	33
5.2	Electrical Specifications.....	34
5.2.1	Power Consumption .....	34
5.2.2	Electrical Input Protection .....	34
5.2.3	Electrical Outputs.....	34
5.3	Mechanical Specifications .....	35
5.4	Environmental Specifications .....	36
5.4.1	High Temperature .....	36
5.4.2	Low Temperature.....	36
5.4.3	Humidity.....	36
5.4.4	Enclosure.....	36
5.4.5	Water and Dust .....	36
5.4.6	Vibration.....	36
5.4.7	Electromagnetic Compatibility (EMC) .....	37
<b>6</b>	<b>Installation Instructions.....</b>	<b>39</b>
6.1	Introduction .....	39
6.2	General Considerations .....	39
6.2.1	Personnel.....	39
6.2.2	Required Tools.....	39
6.2.3	Site Requirements .....	39

6.2.4	The Source and Detector .....	40
6.2.5	Tips for Selecting a Gas Detector Location .....	40
6.2.6	Separation Distances .....	40
6.2.7	Wiring .....	41
6.3	Preparations for Installation .....	41
6.3.1	General .....	41
6.3.2	Equipment .....	41
6.3.3	Unpacking the Product.....	42
6.4	Certification Instructions .....	43
6.4.1	General Instructions.....	43
6.4.2	Special Conditions for Safe Use.....	44
6.5	Conduit/Cable Installation .....	44
6.6	Detector/Source Mounting.....	45
6.6.1	Tilt Kit .....	45
6.6.2	Detector/Source Installation.....	45
6.7	Detector Wiring .....	45
6.8	Detector Terminal Wiring .....	49
6.9	Flash Source Wiring.....	49
6.9.1	Wiring .....	49
6.9.2	Terminal Wiring .....	50
<b>7</b>	<b>Operating Instructions .....</b>	<b>51</b>
7.1	SafEye Operation .....	51
7.2	Alignment of Unit.....	51
7.3	Powering up the System .....	52
7.4	Safety Precautions .....	53
7.5	Signal Verification .....	53
7.5.1	Signal Values Limitation.....	53
7.6	Zero Calibration.....	54
7.7	Functional Check.....	55
<b>8</b>	<b>Maintenance Instructions .....</b>	<b>57</b>
8.1	General Maintenance .....	57
8.2	Periodic Maintenance.....	57
8.2.1	Routine Optical Surface Cleaning .....	57
8.2.2	Signal Verification .....	58
8.2.3	Functional Check of Unit .....	58

<b>9 Troubleshooting .....</b>	<b>59</b>
<b>Appendix A: Wiring Configurations .....</b>	<b>61</b>
A.1 RS-485 Communication Network .....	64
<b>Appendix B: Accessories .....</b>	<b>65</b>
B.1 Tilt Mount .....	65
B.2 Pole Mount (U-Bolt 4-5 inch) .....	65
B.3 Pole Mount (U-Bolt 2-3 inch) .....	65
B.4 Wall Mount .....	65
B.5 Commissioning Kit .....	65
B.6 HART Handheld Diagnostic Unit .....	66
B.7 HART Handheld Harness Kit .....	66
B.8 USB/RS-485 Harness Converter Kit .....	66
B.9 Protective Cover .....	66
<b>Appendix C: SIL-2 Features .....</b>	<b>67</b>
Safety Relevant Parameters .....	67
General Conditions for Safe Use .....	67
<b>Technical Support .....</b>	<b>70</b>



## List of Figures

Figure 1: P/N Definition of Quasar 900	23
Figure 2: Flash Source .....	24
Figure 3: Detector .....	25
Figure 4: Tilt Mount .....	46
Figure 5: Detector and Tilt Mount Assembly.....	47
Figure 6: Detector with Cover Removed .....	48
Figure 7: Source with Cover Removed .....	50
Figure 8: Magnetic Mode Selector.....	54
Figure 9: Detector Wiring Terminal.....	61
Figure 10: Source Wiring Terminal .....	62
Figure 11: 0–20mA Sink 4-Wire .....	63
Figure 12: 0–20mA Non-Isolated Sink 3-Wire .....	63
Figure 13: 0–20mA Source 3-Wire .....	64
Figure 14: RS-485 Networking for Wiring Option 3 .....	64

## List of Tables

Table 1: Gas Concentrations Measurement Terms	18
Table 2: Model Numbers and Installation Distances .....	22
Table 3: Detector LED Indications .....	28
Table 4: Source LED Indications.....	29
Table 5: Standard (default) 0–20mA Current for the Gas Channel .....	29
Table 6: Detector Default Setup.....	31
Table 7: Source Default Setup .....	31
Table 8: Detection Distance Range .....	33
Table 9: Detector and Source Maximum Power Consumption .....	34
Table 10: Tools .....	39
Table 11: Separation Distances.....	40
Table 12: Tilt Mount Kit.....	45
Table 13: Wiring Options.....	49
Table 14: Flash Source Wiring Options.....	50
Table 15: Maintenance Channel Limitation Values .....	53
Table 16: Troubleshooting .....	59
Table 17: Check Filters .....	65



# 1 About this Guide

This manual describes the Quasar 900 Open-Path Gas Detection System and its features and provides instructions how to install, operate, and maintain the detector.

**Note:**

This user guide should be carefully read by all individuals who have or will have responsibility for using, maintaining or servicing the product.

---

This guide includes the following chapters and appendices:

- **Chapter 1, About this Guide**, details the layout of the guide, includes the release history, a glossary and abbreviations, and explains how notifications are used in the guide.
- **Chapter 2, Product Overview**, provides a general introduction and overview of the product and the guide, with a brief description of its content.
- **Chapter 3, Technical Description**, describes the detector's theory of operation.
- **Chapter 4, Operating Modes**, describes the detector's operation modes, user interface and indications.
- **Chapter 5, Technical Specifications**, describes the detector's electrical, mechanical and environmental specifications.
- **Chapter 6, Installation Instructions**, describes how to install the detector, including wiring and mode settings.
- **Chapter 7, Operating Instructions**, describes the operating instructions and power-up procedures.
- **Chapter 8, Maintenance Instructions**, describes the maintenance and support procedures.
- **Chapter 9, Troubleshooting**, describes the solutions to problems that may arise with the detector.
- **Appendix A, Wiring Configurations**, provides wiring diagrams for installation.
- **Appendix B, Accessories**, provides a list of accessories available for the Quasar 900 Open-Path Gas Detection System.
- **Appendix C, SIL-2 Features**, details the special conditions for compliance with the requirements of EN 61508 for SIL-2.

## 1.1 Release History

Rev	Date	Revision History	Prepared by	Approved by
6	February 2013	First Release	Ian Buchanan	Eric Zinn
7	June 2013	Second release	Ian Buchanan	Eric Zinn
8	August 2013	Third Release	Ian Buchanan	Eric Zinn
9	January 2014	Fourth Release	Ian Buchanan	Eric Zinn
10	August 2014	Fifth Release	Ian Buchanan	Eric Zinn
11	January 2015	Sixth Release	Ian Buchanan	Eric Zinn
12	January 2017	Seventh Release	Jay Cooley	Ian Buchanan
13	February 2017	Eighth Release	Jay Cooley	Ian Buchanan
Am	March 2018	Ninth Release	Michal Heller	Udi Tzuri
An	February 2020	Tenth Release	Michal Heller	Udi Tzuri

## 1.2 Glossary and Abbreviations

Abbreviation/Term	Meaning
Analog Video	Video values are represented by a scaled signal
ATEX	Atmosphere Explosives
AWG	American Wire Gauge
BIT	Built-In-Test
CMOS	Complementary Metal-Oxide Semiconductor image sensor
Digital Video	Each component is represented by a number representing a discrete quantization
DSP	Digital Signal Processing
EMC	Electromagnetic Compatibility
EMI	Electromagnetic Interference
EOL	End of Line
FOV	Field of View
HART	Highway Addressable Remote Transducer – communications protocol
IAD	Immune at Any Distance
IECEX	International Electro-Technical Commission Explosion
IP	Internet Protocol
IPA	Isopropyl Alcohol
IR	Infrared

Abbreviation/Term	Meaning
IR3	Refers to the 3 IR sensors in the VID
JP5	Jet Fuel
LED	Light Emitting Diode
MODBUS	Serial communications protocol using Master-Slave messaging
N/A	Not Applicable
N.C.	Normally Closed
NFPA	National Fire Protection Association
N.O.	Normally Open
NPT	National Pipe Thread
NTSC	National Television System Committee (a color encoding system)
PAL	Phase Alternation by Line (a color encoding system)
P/N	Part Number
RFI	Radio Frequency Interference
RTSP	Real Time Streaming Protocol
SIL	Safety Integrity Level
UNC	Unified Coarse Thread
VAC	Volts Alternating Current

## 1.3 Notifications

This section explains and exemplifies the usage of warnings, cautions, and notes throughout this guide:



### **Warning:**

This indicates a potentially hazardous situation that could result in serious injury and/or major damage to the equipment.

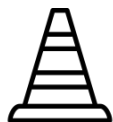

### **Caution:**

This indicates a situation that could result in minor injury and/or damage to the equipment.



### **Note:**

This provides supplementary information, emphasizes a point or procedure, or gives a tip to facilitate operation.



## 2 Product Overview

The SafEye Quasar 900 IR Open-Path Gas Detector employs an advanced Xenon Flash Source and integrated electronics package, both of which are encased in improved stainless steel housings, which provide high quality and performance, fast response, and line-of-sight gas monitoring. The SafEye Quasar 900 Detector is backed by a 3-year warranty.

The Quasar 900 detects ambient combustible gases over a path length of up to 660ft/200m, even in harsh environments where dust, fog, rain, snow, or vibration can cause a high reduction of signal. The SafEye Quasar 900 can maintain operation in up to 90% signal obscuration and  $\pm 0.5$  degree of misalignment.

The Quasar 900 is manufactured only from stainless steel, with a heated optical window to improve performance in ice, snow, and condensation conditions. The programmable functions are available through a RS-485 or HART port used with host software supplied by SPECTREX, and a standard PC or IS handheld unit.

The Quasar source and detector unit enclosures are ATEX and IECEx approved Exd flameproof with an integral segregated rear and an Exe terminal compartment, which avoids exposure of the sensors and electronics to the surrounding environment. The detector also has a plug interface for connection to a handheld PC or HART unit, which meets intrinsically safe standards. Hence the combined approval:

Ex II 2(2) G D

Ex db eb ib [ib Gb] IIB+H2 T4 Gb

Ex tb IIIC T135°C Db

Ta=-55°C to +65°C

This manual provides a full description of the detector and its features. It includes instructions on the installation, operation, and maintenance of the detector.

- To use the WinHost software to change the required functions, and for a description of its maintenance, please refer to *Manual TM 888050*.

To use the HART Protocol to change the required functions and for a description of its maintenance, please refer to *Manual TM 888030*. To set functions, the HART can be connected on the 0-20mA line or through the IS port.



### Warning:

The source and detector are not field-repairable due to the meticulous alignment and calibration of the sensors and the respective circuits. Do not attempt to modify or repair the internal circuits or change their settings, as this will impair the system's performance and void the SPECTREX product warranty.

---





## 3 Technical Description

### 3.1 Features

- Long-range gas detection of up to 660ft/200m
- Detection of methane, ethylene or propane gases
- High sensitivity and fast response to hydrocarbon gases
- Heated optics to improve performance in ice, condensation, and snow conditions
- Continuous operation in extreme or harsh environmental conditions
- Solar blind and immune to industrial environments
- Withstands extreme vibrations
- Standard 0–20mA output
- “Maintenance Call Mode” (3mA)
- HART Protocol: Communication Protocol
- RS-485 Output Modbus compatible with PC Communication Network for a maximum of 247 systems
- Simple 1-person installation, alignment, and calibration
- ATEX and IECEx approved per:
  - Ex II 2(2)G D
  - Ex db eb ib [ib Gb] IIB+H2 T4 Gb,
  - Ex tb IIIC T135°C Db
  - Ta=–55°C to +65°C
- FM/FMC approved per:
  - Class I Div. 1 Group B, C, and D;
  - Class II/III Div. 1 Group E, F, and G
- TR CU/EAC approved per:
  - 1Ex db eb [ib Gb] IIB + H2 T4 Gb X
  - Ex tb IIIC T135°C Db X
  - 55°C ≤ Ta ≤ +65°C
- TUV approved per SIL-2 requirements
- Inmetro (UL) approved
- Functional tested by FM per EN60079-29-4 and approved per FM 6325
- Programmable configuration via the handheld unit

- Fast connection to IS-approved handheld diagnostic/calibration unit
- A 3-year warranty

## 3.2 Applications

The Quasar 900 system is an optical control fence for combustible gases as defined in the product specification, providing perimeter monitoring and early detection in various applications, such as:

- Petrochemical, pharmaceutical, and other chemical storage and production areas
- Flammable chemical storage sites, and hazardous waste disposal areas
- Refineries, oil platforms, pipelines, refueling stations, and fuel storage facilities
- Hazardous loading docks, transportation depots, and shipping warehouses
- Engine rooms
- Compressor and pumping stations
- Test cells
- LNG-LPG Systems
- Offshore Floating Production Storage and Shipping vessels (FPSO), and fixed oil rigs

## 3.3 Principles of Operation

The Quasar system detects gases through dual-spectral range monitoring, analyzing the absorption of radiation caused by gases in the atmosphere, and comparing the ratio to background atmospheric absorption.

### 3.3.1 Definitions of Terms

The following list defines gas concentration measurement terms that are used in this manual:

**Table 1: Gas Concentrations Measurement Terms**

Term	Description
LEL	<b>Lower Explosive Limit:</b> The minimum concentration of a substance (gas/vapor) in air mixture that can be ignited. This mixture is different for every gas/vapor, measured in % of LEL.
LEL.m	Integral of Concentration in LEL units (1 LEL = 100% LEL) and the operation distance in meters (m).

### 3.3.2 Spectral Fingerprint

Each hazardous material is detected at a specific wavelength selected according to its specific spectral absorption or "fingerprint." The detection process involves 2 separate filters: one transmitting radiation that is absorbed by a particular gas, and one that is not sensitive to it.

### 3.3.3 Optical Path

The presence of hazardous airborne vapors, gases, or aerosols in a monitored area is detected when the defined substance crosses/enters the optical path between the radiation source unit and the detector.

Hazardous gases/vapors present in the atmosphere cause absorption of the radiation pulse at specific wavelengths in the optical path between the radiating source and the detector unit. This causes a change in the signal intensity received by the detector, which is translated into an output related to the detector's measuring scale.

The system analyzes the defined open path at the spectral bands specific to the materials being monitored. The Automatic Gain Control (AGC) unit compensates for environmental disturbances such as fog and rain, through a constant comparison with its dual spectral beam.

### 3.3.4 Microprocessor Based

The incoming signals are analyzed by the built-in microprocessor. A sophisticated mathematical algorithm calculates the various functions of the detected signal thresholds. Statistics, ratio algorithms, data communications, diagnostics, and other functions are performed.

### 3.3.5 Gas Sensitivity

The SafEye Quasar 900 Model uses wavelengths around the 2.3 $\mu$  spectral band to measure air flammability potential between the source and detector. At this wavelength, all hydrocarbon materials have an absorption peak. This enables the detector to achieve regular sensitivity of 0–5 LEL.m.

The Quasar 900 detects hydrocarbon gases including methane, ethylene, propane, ethane, butane, and others.

### 3.3.6 Gas Calibration

The Quasar 900 has 3 calibrations that can be changed by function setup:

- Gas 1 – 100% methane
- Gas 2 – 100% propane
- Gas 3 – 100% ethylene

The full scale of methane and propane is 5 LEL.m, while the full scale of ethylene is 8 LEL.m. Gas calibration is available to LEL values defined by NFPA 325 and IEC 60079-20. Instruments certified to ATEX/IECEX, EAC, and Inmetro are calibrated to LEL values defined by the IEC standard, while configurations certified to FM/FMC are calibrated per the NFPA norm.

The full scale of methane and propane is 5 LEL.m.

### 3.3.7 Flash Source

The Xenon Flash Source was originally introduced in the first SafEye development and was designed to overcome false alarms, which were experienced by early generations of the open path system. The new SafEye Quasar 900 employs the latest generation of flash bulbs to provide even more power and an extended operation life.

### 3.3.8 Heated Optics

SafEye Quasar includes heated optics for the detector and source. To improve performance in conditions where there is ice, condensation, or snow, the heater increases the temperature of the optical surface by 5–8°F / 3–5°C above the ambient temperature. The heated optics are configured to automatically operate when the change in temperature requires heating (default).

However, the heated optics can be defined as one of the following modes:

- Not operated (not an option on the source unit)
- On continuously
- Automatic, per temperature change (default)

See *System Setup*, page 30.

When operated “per temperature change,” the user can define the start temperature below which the window will be heated (default is 41°F/5°C). This temperature can be defined from 32°F/0°C – 122°F/50°C. Heating stops when the temperature is 27°F/15°C above the start temperature.

### 3.3.9 HART Protocol

The Quasar 900 uses the HART Protocol.

HART Communication is a bi-directional industrial field communication protocol used to communicate between intelligent field instruments and host systems. HART is the global standard for smart instrumentation, and the majority of smart field devices installed in plants worldwide are HART-enabled.

HART technology is easy to use and very reliable.

Through the HART connection, the SafEye is able to perform:

- Detector setup
- Detector troubleshooting
- Detector health and status

For more details, refer to *Manual TM888030*.

HART communication can be connected on the 0–20mA line or through the IS connection, with a standard handheld unit loaded with the host software and attached by a special harness.

### 3.3.10 Modbus RS-485

For more advanced communications, the Quasar 900 has a RS-485 Modbus-compatible output that provides data communication from a network (up to 247

detectors) to a host computer or universal controller for central monitoring. This feature enables easy maintenance, with local and remote diagnostic tools.

### 3.3.11 Tilt Mount

The newly designed stainless steel tilt mount provides a smaller installation footprint that can conform to limited space constraints, while the sturdy construction maintains alignment even with constant vibration. The improved X and Y axis worm-gear adjustments provide quick and easy alignment for installation and maintenance procedures.

## 3.4 Product Certification

The Open-Path Quasar 900 is approved for the following certifications:

- ATEX, IECEx, page 21
- FM/FMC, page 21
- SIL-2, page 21
- Functional Test, page 22
- TR CU/EAC, page 22
- Inmetro (UL), page 22

### 3.4.1 ATEX, IECEx

The Quasar 900 is ATEX approved per SIRA 12ATEX1212X and IECEx per IECEx SIR 12.0086X per:

- Ex II 2(2)G D  
Ex db eb ib [ib Gb] IIB+H2 T4 Gb  
Ex tb IIIC T135°C Db
- T Ambient -55°C to +65°C

This product is suitable for use in hazardous zones 1 and 2 with IIB+H2 group vapors present, and zones 21 and 22 with IIIC combustible dust types.

### 3.4.2 FM/FMC

The Quasar 900 is approved to FM/FMC Explosion Proof per:

- Class I, Div. 1 Group B, C and D, T6 -8°F/-50°C ≤ Ta ≤ 149°F/65°C
- Dust Ignition Proof – Class II/III Div. 1, Group E, F, and G
- Ingress Protection – IP66 and IP68, NEMA 250 Type 6P

IP68 is rated for 2-meter depth for 45 minutes.

### 3.4.3 SIL-2

The Quasar 900 is TUV approved for SIL-2 requirements per IEC 61508.

According to SIL-2 requirements, the alert condition can be implemented by an alert signal via the 0–20mA current loop.

For more details and guidelines on configuring, installing, operating, and servicing, see *SIL-2 Features*, and TUV report no. 968/EZ 619.00/13.

### 3.4.4 Functional Test

The Quasar 900 was functional approved per FM 6325.

The Quasar 900 was functional tested by FM per EN60079-29-4.

### 3.4.5 TR CU/EAC

The Quasar 900 is in compliance with the standard TR CU 012/2011 per:

1Ex db eb ib [ib Gb] IIB+H2 T4 Gb X

Ex tb IIIC T135°C Db X

-55°C ≤ Ta ≤ +65°C

For more details, see TR CU certificate No. TR CU C- US.MIO62.B.05536.

### 3.4.6 Inmetro (UL)

The Quasar 900 is in compliance with the standards ABNT NBR IEC 60079-0, ABNT NBR IEC 60079-1, ABNT NBR IEC 60079-7, ABNT NBR IEC 60079-11, ABNT NBR IEC 60079-31, and INMETRO decree No. 179 as of May 18th, 2010. Further details may be found on Certificate of Compliance No. UL-BR 16.106XX.

## 3.5 Models and Types

The Quasar 900 is available in 4 models. Each model has the same detector but a different source. This allows for detection at distances of 7–200m / ~23–656ft.

**Table 2: Model Numbers and Installation Distances**

Model No.	Detector	Source	Min. Installation Distance (ft/m)	Max. Installation Distance (ft/m)
901	QR-X-11X	QT-X-11X	23/7	66/20
902	QR-X-11X	QT-X-21X	50/15	132/40
903	QR-X-11X	QT-X-31X	115/35	330/100
904	QR-X-11X	QT-X-41X	265/80	660/200

The Quasar 900 can be ordered as separate parts: source (P/N QT-XX1X), detector (P/N QR-X11X), and commissioning kit (P/N 888247-X). Refer to Figure 1.

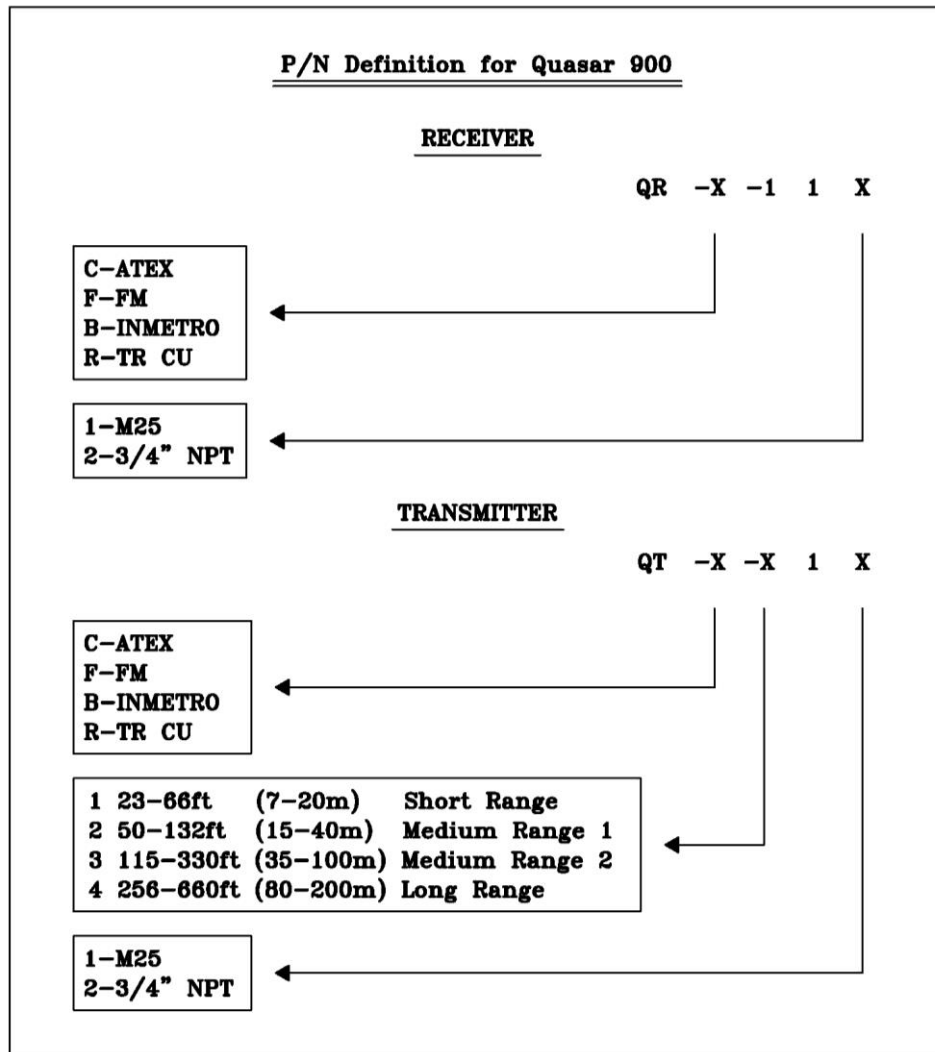

**Figure 1: P/N Definition of Quasar 900**

## 3.6 Description

The SafEye system is comprised of 2 main units:

- The Flash Infrared Source (Transmitter)
- The Infrared Detector (Receiver)

Quasar 900 detects gases over an open path transmitted from the flash source to the detector.

### 3.6.1 Flash Source Unit

The flash source unit emits IR radiation pulses at the rate of 2 pulses per second. The pulse width (5–10µsec) is very powerful. The front of the source unit has a lens that collimates the IR beam for maximum intensity. The front window is heated to improve performance in ice, condensation, and snow conditions.

There are 4 source types:

- For Short Range – 901 – source P/N QT-X-11X
- For Medium Range 1 – 902 – source P/N QT-X-21X
- For Medium Range 2 – 903 – source P/N QT-X-31X
- For Long Range – 904 – source P/N QT-X-41X

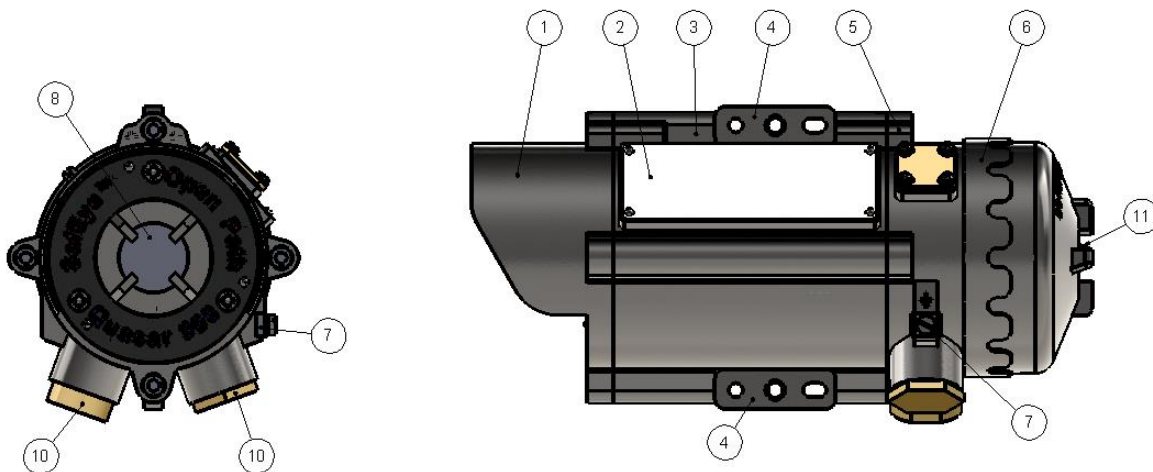

<b>1</b>	Front window section	<b>6</b>	Back cover
<b>2</b>	Label	<b>7</b>	Earth terminal
<b>3</b>	Main housing	<b>8</b>	Front window
<b>4</b>	Mounting plate	<b>10</b>	Cable inlet
<b>5</b>	Junction box	<b>11</b>	Indicator LED

**Figure 2: Flash Source**

The sources for models 901, 902, and 903 are the same electronically and optically. The only distinction between them is that each detector apparatus is suitable for a different distance.

The source for model 904 has different optics with a different XENON lamp source.

### 3.6.2 Detector Unit

The detector receives the transmitted pulsed radiation signals from the flash source. The signals are then amplified and fed into an analog-to-digital signal converter to be processed by the internal microprocessor. When the signals drop below a prescribed level, the internal microprocessor compensates for them. This



allows the signals to be maintained even in severe weather conditions. The data is sent to the output interface section.

The front window of the detector is heated to improve performance in ice, condensation, and snow conditions.

The P/N QR-X-11X Detector is suitable for Quasar models 901, 902, 903, and 904.

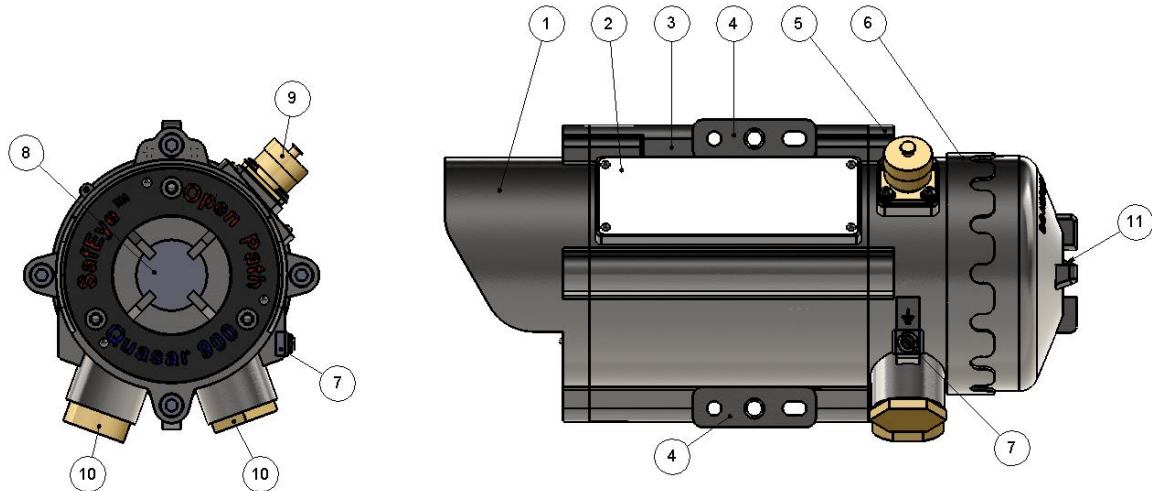

<b>1</b>	Front window section	<b>7</b>	Earth terminal
<b>2</b>	Label	<b>8</b>	Front window
<b>3</b>	Main housing	<b>9</b>	Handheld fast connection
<b>4</b>	Mounting plate	<b>10</b>	Cable inlet
<b>5</b>	Junction box	<b>11</b>	Indicator LED
<b>6</b>	Back cover		

**Figure 3: Detector**



## 4 Operating Modes

### 4.1 Operational Modes

The Quasar 900 has 4 operational modes:

- Normal Mode
- Maintenance Call Mode (3mA Output)
- Fault Mode
- Zero Calibration Mode (1mA Output)

#### 4.1.1 Normal Mode

This mode is used for gas detection. In normal mode, the following statuses are possible:

- Normal (N) - Signal received from gas detection is at safe levels.
- Warning (W) - Gases have been detected at warning levels.
- Alarm (A) - Gases have been detected at alarm levels.



**Note:**

For the standard 0–20mA output, the warning and alarm levels are not relevant. The user chooses these alarm levels at the controller. The output detector will be 4mA at zero reading and 20mA for full-scale reading.

---

Warning and alarm states can be seen through the LED, RS-485, and HART.

If the RS-485 output is used, the detector changes its status from "N" to "W" at warning level, and to "A" at alarm level.

#### 4.1.2 Maintenance Call Mode (3mA Output)

This mode indicates a low signal or low signal ratio that may be caused by a dirty window, misalignment, poor source, or that one of the detector's parameters is at the "limit" value.

The detector continues to operate, reading any gas present, but provides a (3mA) pre-warning signal that a maintenance procedure is required.

#### 4.1.3 Fault Mode

In fault mode, there are 3 fault types. In all fault types, the LED flashes yellow at 4Hz:

- **Misalignment (2.5mA Output)**

This occurs due to poor alignment. Detection is no longer possible.

- **Fault 1 (2mA Output)**

Fault 1 is due to a blockage, very low signal, partial obscuration, or full beam block. Detection is no longer possible. The detector's proper operation can be restored (auto reset) during operation if the condition causing the problem is removed or resolved. There is a delay of 60sec after the fault before switching to this mode. This delay is important to eliminate momentary obscuration due to passing through the beam.

- **Fault 2 (1mA Output)**

Detection is disabled due to an electrical/software operational failure, central device (memory/processor) fault, or low voltage. A fault of this type causes the detector to cease operation.

If there is a fault in the 0–20mA loop, the output is 0mA.

#### 4.1.4 Zero Calibration Mode (1mA Output)

This mode calibrates the base level, from which gas is detected, to zero.

It should only be performed when the following criteria are met:

- No combustible gases are present
- A clear path exists between the flash source and detector
- Clear weather conditions

Zero calibration must be performed after installation, re-alignment, or window cleaning, using the handheld unit or host software on a PC.

## 4.2 Visual Indicators

One 3-color LED indicator is located in the back of the detector/source and can be seen through the back cover window. Refer to Figure 2 and Figure 3, Item 11.

The detector statuses are listed in Figure 2.

**Table 3: Detector LED Indications**

Detector Status	LED Color	LED Mode
Fault	Yellow	4Hz – flashing
Alignment/Standby	Yellow	1Hz – flashing
Zero Calibration	Yellow	Constant
Normal	Green	1Hz – flashing
Warning	Red	2Hz – flashing
Alarm	Red	Constant

The source statuses are listed in Table 4.

**Table 4: Source LED Indications**

Source Status	LED Color	LED Mode
Fault	Yellow	4Hz – flashing
Normal	Green	1Hz – flashing

## 4.3 Output Signals

The SafEye system provides the following outputs:

- 0–20mA Current Output, page 29
- RS-485 Interface, page 29

### 4.3.1 0–20mA Current Output

The 0–20mA output provides the detector status measurement with a continuous reading of exact gas concentration.

The 0–20mA output functions as current Sink, but it can be configured as Source (see *Wiring Configurations*).

The maximum permitted load resistance for the 0–20mA output is 500Ω.

**Table 5: Standard (default) 0–20mA Current for the Gas Channel**

Current Reading	Status and Description
0mA +0.2mA	Fault in 0–20mA loop
1mA ±0.2mA	Zero calibration (in progress), Fault 2
2mA ±0.2mA	Fault 1 (non-critical)
2.5mA ± 0.2mA	Misalignment fault
3mA ±0.2mA	“Maintenance call”
4mA±0.2mA	No gas present
4–20mA	Continuous measuring of gas concentration at a range between 0 and full scale. For methane and propane, this translates to 3.2mA per LEL.m, and for ethylene to 2mA per LEL.m.
21mA	Concentration is over the range limit (more than full-scale concentration)

### 4.3.2 RS-485 Interface

The detector has an RS-485 Modbus-compatible input/output that can send data communication to a PC loaded with the appropriate host software, and receive data or control commands from the PC.

## 4.4 System Setup

This section includes the following topics:

- Detection Function Programming, page 30
- Detection Setup Function, page 30
- Detector Default Setup, page 31

### 4.4.1 Detection Function Programming

The SafEye Quasar 900 incorporates several functions that can be set by the customer, using:

- Host software: Refer to *Manual TM 888050* for programming instructions.
- The HART handheld diagnostic unit (P/N 888810) provides an easy, economical connection to the quick plug. This unit provides verification, status, and instructions for correcting the detector's parameters. It also includes a harness and a special host for maintenance and commissioning.

### 4.4.2 Detection Setup Function

See *Detector Default Setup*, page 31 for default settings.

Setup includes the following options:

- Gas Calibration, page 30
- **Error! Reference source not found.**, page **Error! Bookmark not defined.**
- Address Setup, page 30
- Heated Optics Operation, page 31

#### 4.4.2.1 Gas Calibration

Three gas types can be selected for maximum compatibility with the required measured gas/es.

Gas Types:

- Methane – full scale 5 LEL.m.
- Propane – full scale 5 LEL.m.
- Ethylene – full scale 8 LEL.m.

These 3 calibrations are standard calibrations.

#### 4.4.2.2 Address Setup

The detector provides up to 247 addresses that can be used with the RS-485 communication link.

### 4.4.2.3 Heated Optics Operation

The heated optics for the detector unit can be defined as one of the following modes:

- Off - Not operated
- On - Operated continuously
- Auto - On, per temperature change (default)

In Auto mode, the start temperature below which the window will be heated can be defined. Heating stops when the temperature is 27°F/15°C above the start temperature.

The temperature can be defined between 32–122°F / 0–50°C.

This feature applies only to the detector.

The source heated optics must be defined when the detector is ordered as 1 of 2 options:

- Heated continuously
- Or
- Start heating below 41°F/5°C (default)

### 4.4.3 Detector Default Setup

The detector has 4 functions that can be programmed according to customer requirements, either at the factory or at the customer facility, using a PC software host or a handheld unit. The standard setup is as follows:

**Table 6: Detector Default Setup**

Function	Setup
Gas Type	1
Automatic BG Calibration	Enabled
Heat Mode	Auto
Heat On	5

**Table 7: Source Default Setup**

Function	Setup
Heat Mode	Auto
Heat On	5

The source default can be changed with the same host.





## 5 Technical Specifications

### 5.1 General Specifications

**Detected Gases:** Simultaneous detection of C1-C8 flammable gases  
**Detection Distance Range:** Table 8

**Table 8: Detection Distance Range**

Model No.	Detector	Source	Min. Installation Distance (ft/m)	Max. Installation Distance (ft/m)
901	QR-X-11X	QT-X-11X	23/7	66/20
902	QR-X-11X	QT-X-21X	50/15	132/40
903	QR-X-11X	QT-X-31X	115/35	330/100
904	QR-X-11X	QT-X-41X	265/80	660/200

**Response Time:** 3sec to T90

**Spectral Response:** 2.0–3.0 micron

**Sensitivity Range:**

		Full Scale LEL.m	Warning LEL.m	Alarm LEL.m
Gas 1	Methane	5	1	3
Gas 2	Propane	5	1	3
Gas 3	Ethylene	8	1.6	4.8

Methane, propane, and ethylene at LEL levels defined by NFPA 325 and IEC 60079-20.

**Field of View:** Line of sight

**Alignment Tolerance:**  $\pm 0.5^\circ$

**Drift:**  $\pm 7.5\%$  of the reading or  $\pm 4\%$  of the full scale (whichever is greater)

**Minimum Detectable Level:** 0.15 LEL.m

**Temperature Range:**  $-67^\circ\text{F}/-55^\circ\text{C}$  to  $+149^\circ\text{F}/+65^\circ\text{C}$

**Immunity to False Alarm:** Does not produce a false alarm and is not influenced by solar radiation, hydrocarbon flames, or other external IR radiation sources

## 5.2 Electrical Specifications

**Operating Voltage:** 18–32VDC

### 5.2.1 Power Consumption

**Table 9: Detector and Source Maximum Power Consumption**

	Without Heated Optic (Max.)	With Heated Optic (Max.)
<b>Detector</b>	200mA	250mA
<b>Source</b>	200mA	250mA

### 5.2.2 Electrical Input Protection

The input circuit is protected against voltage-reversed polarity, voltage transients, surges, and spikes, according to EN50270.

### 5.2.3 Electrical Outputs

#### 5.2.3.1 0–20mA Current Output

The 0–20mA is an isolated Sink option. This output can also be configured as Source (see *Wiring Configurations*).

The maximum permitted load resistance is 500Ω.

#### 5.2.3.2 Communication Network

The detector is equipped with an RS-485 communication link that can be used in installations with computerized controllers.

Communication is compatible with the Modbus protocol:

- This protocol is standard and widely used.
- The protocol enables continuous communication between a single standard Modbus controller (master device) and a serial network of up to 247 detectors.
- The protocol enables connections between different types of SPECTREX detectors or other Modbus devices to the same network.

#### 5.2.3.3 HART Protocol

The HART protocol is a digital communication signal at low levels in addition to the 0–20mA.

This bi-directional field communication protocol is used to communicate between intelligent field instruments and the host system.

Through the HART protocol, the detector can:

- Display setup
- Reconfigure setup
- Display detector status and definition

- Perform detector diagnostics
- Troubleshoot

## 5.3 Mechanical Specifications

**Enclosure:** The detector, source, and tilt mount are stainless steel 316 electrochemical and passivated coating

**Explosion Proof:** ATEX and IECEx Ex II 2(2) G D,  
Ex db eb ib [ib Gb] IIB+H2 T4 Gb  
Ex tb IIIC T135°C Db  
Ta= -55°C to +65°C

FM/FMC Class I Div. 1 Groups B, C, and D  
Class II/III Div. 1 Groups E, F, and G  
-58°F/-50°C ≤ Ta ≤ 149°F/65°C

**Functional Testing:** Approved per FM 6325  
Tested by FM per EN60079-29-4

**Water and Dust Tight:** IP 66 and IP 68  
IP68 is rated for 2-meter depth for 45 minutes  
NEMA 250 type 6p

**Electrical Modules:** Conformal coated

**Electrical Connection:** (2 options – specified at time of order)  
2 X M25 (ISO)

2 X 3/4" – 14 NPT conduits

**Dimensions:**

Detector	10.5" x 5.1" x 5.1"	267 x 130 x 130 mm
Source	10.5" x 5.1" x 5.1"	267 x 130 x 130 mm
Tilt Mount	4.7" x 4.7" x 5.5"	120 x 120 x 40 mm

**Weight:**

Detector	11lb	5kg
Source	11lb	5kg
Tilt Mount	4.2lb	1.9kg

## 5.4 Environmental Specifications

The SafEye system is designed to withstand harsh environmental conditions. The source and detector units compensate for adverse conditions while maintaining accuracy.

### 5.4.1 High Temperature

The SafEye system conforms to DNVGL-CG-0339, class D.

**Operating Temperature:** +149°F/+65°C

**Storage Temperature:** +149°F/+65°C

### 5.4.2 Low Temperature

The SafEye system conforms to DNVGL-CG-0339, class D.

**Operating Temperature:** -67°F/-55°C

**Storage Temperature:** -67°F/-55°C

### 5.4.3 Humidity

The SafEye system conforms to DNVGL-CG-0339, class B.

### 5.4.4 Enclosure

The SafEye system conforms to DNVGL-CG-0339, class C.

### 5.4.5 Water and Dust

- IP66 per EN60529
- IP68 per EN60529

**Dust:** Completely protected against dust.

**Liquids:** Protected against immersion between 15cm and 1m in depth. Protected against water jets from all directions.

### 5.4.6 Vibration

The SafEye system conforms to DNVGL-CG-0339, class B.

## 5.4.7 Electromagnetic Compatibility (EMC)

This product is in conformance with EMC per EN50270:

<b>Radiated Emission:</b>	EN55022
<b>Conducted Emission:</b>	EN55022
<b>Radiated Immunity:</b>	EN61000-4-3
<b>Conducted Immunity:</b>	EN61000-4-6
<b>ESD:</b>	EN61000-4-2
<b>Burst:</b>	EN61000-4-4
<b>Surge:</b>	EN61000-4-5
<b>Magnetic Field:</b>	EN61000-4-8

To fully comply with EMC directive 2014/30/EU and protect against interference caused by RFI and EMI, the cable to the detector must be shielded and the detector must be grounded. The shield should be grounded at the detector end.



## 6 Installation Instructions

### 6.1 Introduction

The detector and flash source units can be installed and maintained using general-purpose common tools and equipment. The installation procedure must be performed by suitably qualified personnel.

This section does not attempt to cover all of the standard practices and codes of installation. Rather, it emphasizes specific points of consideration and provides some general rules for suitably qualified personnel. Special safety precautions are stressed wherever applicable.

### 6.2 General Considerations

#### 6.2.1 Personnel

Only suitably qualified personnel, familiar with the local codes and practices and trained for gas detection maintenance, should be employed. Wiring should only be performed or supervised by someone with knowledge of electronics and in particular wiring installation.

#### 6.2.2 Required Tools

The detector can be installed using general-purpose common tools and equipment. Table 10 lists the specific tools required to install the detector.

**Table 10: Tools**

Tools	Function
Hex key 10mm	Mount the detector on the tilt mount
Hex key 3/16"	Align the detector
Hex key 5/16"	Screw detector plug
Flat screwdriver 4mm	Connect the ground terminal
Flat Screwdriver 2.5mm	Connect wires to the terminal blocks

#### 6.2.3 Site Requirements

When selecting a site location and position for the SafEye system, the following points must be considered:

- Whether the gas being monitored is heavier or lighter than air
- The individual site requirements
- The detector should have a direct view of the source
- The mounting point for each item should be secure and stable with minimal vibrations

- Equipment should be either mounted in a position where it cannot be knocked out of alignment, or it is guarded from physical impact

## 6.2.4 The Source and Detector

The model of detector suitable should be selected according to the length of open path to be monitored. To allow for ageing of the source and a reduction of the IR signal due to adverse weather, it is recommended to use a detector that is not at the limit of its operating range.

The open path between the source and detector and the immediate surroundings should be kept clear of obscuration that might hinder the free movement of air in the protected area, or block the infrared beam.

## 6.2.5 Tips for Selecting a Gas Detector Location

The following are some tips for selecting gas detector locations, in order to provide the best detection coverage:

- For heavier-than-air gases: below potential leak sources.
- For lighter-than-air gases: above potential leak sources.
- Along the expected leak trajectory: near leak sources, considering prevailing wind directions.
- Between leak sources and potential ignition sources.
- In areas with expected heavy fog, rain, or snow, consider the effects of long-range installation and install the detector at a shorter range with the maximum intensity model available.

## 6.2.6 Separation Distances

To avoid cross talk between adjacent Open Path Gas Detector Systems where Transmitters are installed on the same side, keep the relevant separation distance between the neighboring OPGD systems according to the installation lengths as listed in Table 11.

**Table 11: Separation Distances**

Installation Line of Sight Distance, m (ft.)	Minimum Separation, m (ft)
10 (33)	1 (3.3)
20 (66)	1.5 (5)
30 (98)	2.5 (6.5)
40 (131)	3.5 (11.5)
50 (164)	4.5 (15)
60 (197)	5 (16.5)
70 (230)	6 (20)
80 (262)	7 (23)



Installation Line of Sight Distance, m (ft.)	Minimum Separation, m (ft)
90 (295)	8 (26)
100 (328)	8.5 (28)
110 (361)	9 (29.5)
120 (394)	10 (33)
130 (427)	10.5 (34.5)
140 (459)	11.5 (38)
150 (492)	13 (42.5)
160 (525)	14.5 (47.5)
170 (558)	15 (49)
180 (591)	15.5 (51)
190 (623)	16 (52.5)
200 (656)	16.5 (54)

## 6.2.7 Wiring

- For wiring, use color-coded conductors, suitable wire markings, or labels. The wire cross-section must be between 0.5–2.5mm<sup>2</sup> / 28–14AWG.
- The selected wire gauge should be based on the number of detectors used on the same loop, and the distance from the control unit. The maximum number of wire connections in a terminal is 2 wire cross-sections, each of 1mm<sup>2</sup>.
- To fully comply with EMC directive and protect against interference caused by RFI and EMI, the cable to the detector must be shielded and the detector must be grounded. The shield should be grounded at the detector end.

## 6.3 Preparations for Installation

### 6.3.1 General

Installation should comply with local, national, and international regulations and norms, as applicable to gas detectors and approved electrical devices installed in hazardous areas. The detectors can be installed with general-purpose common tools and equipment.

### 6.3.2 Equipment

In addition to this manual, the system should include the following:

- Detector Unit - QR-X-11X (See Models and Types, page 22)
- Source Unit - QT-X-X1X (See Models and Types, page 22)
- 2 Tilt Mount Bases - P/N 888270
  - 1 base is used for the detector
  - 1 base is used for the flash source

- Commissioning Kit – there are 3 commissioning kit options:
  - 888247-1 for methane calibration
  - 888247-2 for propane calibration
  - 888247-3 for ethylene calibration

The commissioning kit includes:

- Alignment tool Kit - P/N 888210
- Function Check Filters - P/N 888260-1÷6
- Other accessories are available (per customer request):
  - Pole Mount (U-Bolt 5 inch) - P/N 799225
  - Pole Mount (U-Bolt 2-3 inch) - P/N 888140
  - Wall Mount - P/N 799255
  - HART Handheld Diagnostic Unit - P/N 888810
  - HART Handheld Harness Kit - P/N 888815
  - USB/RS-485 Harness Converter Kit - P/N 794079
  - Protective Cover - P/N 888263

For additional details, see *Wiring Configurations*.

### 6.3.3 Unpacking the Product

Upon receipt of the detector, check and record the following:

- 1** Verify that the model matches the purchase order.
- 2** Record the part number (P/N) and serial number of the detectors and source units, and the installation date in an appropriate logbook.
- 3** Open the container package immediately, prior to detector installation, and visually inspect the detectors, sources, and accessories.
- 4** Verify that all components required for the detector installation are readily available before commencing the installation. In the event that the installation is not completed in a single session, secure and seal the detectors and conduits.

## 6.4 Certification Instructions

### 6.4.1 General Instructions

---

**Warning:**

Do not open the detector, even when isolated, when a flammable atmosphere is present.

---

Use the following certification instructions:

- The cable entry point may not exceed 182°F/83°C. Suitable precautions should be taken when selecting the cable.
- The marking of the equipment is:  
Ex II 2(2)G D  
Ex db eb ib [ib Gb] IIB+H2 T4 Gb  
Ex tb IIIC T135°C Db
- The equipment may be used with flammable gases and vapors with apparatus groups IIA and IIB +H2 T4 in the ambient temperature range -67°F/-55°C to +149°F/+65°C.
- Installation should be carried out by suitably trained personnel, in accordance with the applicable code of practice, e.g. EN 60079-14:1997.
- Inspection and maintenance of this equipment should be carried out by suitably trained personnel in accordance with the applicable code of practice, e.g. EN 60079-17.
- Repair of this equipment should be carried out by suitably trained personnel, in accordance with the applicable code of practice, e.g. EN 60079-19.
- The certification of this equipment relies upon use of the following materials in its construction:
  - **Enclosure:** Stainless Steel 316
  - **Window:** Sapphire Glass
  - **Seals:** EPDM
- If the equipment is likely to come into contact with aggressive substances as described below, then it is the responsibility of the user to take suitable precautions to prevent the equipment from being adversely affected, thus ensuring that the type of protection provided by the equipment is not compromised.
  - Examples of aggressive substances: acidic liquids or gases that may attack metals, solvents that may affect polymeric materials.
  - Examples of suitable precautions: routine inspections, establishing resistance to specific chemicals from the material's data sheets.

## 6.4.2 Special Conditions for Safe Use

- The dimensions of the flameproof joints differ from the relevant minimum or maximum values required by Table 2 of IEC/EN 60079-1:2007 for IIB + H<sub>2</sub>, as detailed below:

Flamepath Description	Type of Joint	Minimum Width "L" (mm)	Maximum Gap "ic" (mm)
Cylindrical section of spigot (both ends of Ex d compartment)	Cylindrical	15	0.08
30mm diameter window fitted against enclosure	Flanged	10.7	0.02
39.5mm diameter window fitted against enclosure	Flanged	10	0.02

- Gaps, "ic," should not be modified to be any larger, and widths, "L," should not be modified to be any shorter than the values shown in the table above.
- Connections to the IS port on the side of the detector enclosure should be made using equipment that maintains the intrinsically safe levels of protection.
- The Um should be installed in accordance with one of the following:
  - The Um is 18–32VDC, in a SELV/PELV system
  - Via a safety isolating transformer, complying with the requirements of IEC 61588-2-6 or technically equivalent standard
  - Directly connected to apparatus, complying with IEC 60950, IEC 61010-1, or technically equivalent standard
  - Fed directly from cells or batteries

## 6.5 Conduit/Cable Installation

The conduit and cable installation must comply with the following guidelines:

- To avoid water condensation in the detector, install the detector with the conduits/cable entries facing downward.
- Use flexible conduits/cables for the last portion that connects to the detector.
- When pulling the cables through the conduits, ensure that they are not tangled or stressed. Extend the cables about 12"/30cm beyond the detector location to accommodate wiring after installation.
- After the conductor cables have been pulled through the conduits, perform a continuity test.

## 6.6 Detector/Source Mounting

Mount the detector source with the tilt mount kit, P/N 888270. The tilt mount enables the detector to be rotated up to 60° in all directions, with a fine alignment of up to 10°.

### 6.6.1 Tilt Kit

The following contents are included with the tilt mount kit (P/N 888270):

**Table 12: Tilt Mount Kit**

Item	Qty	Type/Model
Tilt mount	1	888269
Screw	1	M10 x 1.5
Spring washer	1	No. 10

### 6.6.2 Detector/Source Installation

(Figure 4 and Figure 5)

The detector and the source can be installed in 2 ways with the same tilt mount.

■ **To install the detector/source:**

- 1 Place the tilt mount holding plate (Item 1) in its designated location and secure it with 4 fasteners through 4 holes of an 8.5mm diameter.



**Notes:**

- Skip this step if the tilt mount is already installed.
- Detector removal for maintenance purposes does not require tilt mount removal.

- 2 Place the detector, with its conduit/cable inlets pointing downwards, on the detector holding plate of the tilt mount (Item 2). Secure the detector with M10 x 1.5 screws with No. M10 spring washers (9, 10). Secure the detector to the tilt mount using Hex Key No. 7 for M10 x 1.5 screws (Item 9).
- 3 Repeat Steps 1–2 for installing the source.

## 6.7 Detector Wiring

■ **To install the detector wiring:**

- 1 Release the back cover secure bolt (Figure 5, Item 15), and open the detector back cover (Figure 5, Item 14). The chamber is now exposed.
- 2 Remove the protective plug mounted on the detector conduit/cable entry inlet and pull the wires through the detector inlet (Figure 6, Item 4). Use a 3/4" – 14 NPT or M25x1.5 explosion-proof conduit connection/cable gland to assemble the cable/explosion-proof conduit to the detector.

- 3** Connect the wires to the required terminals (Figure 6, Item 2) according to the wiring diagram. See *Detector Terminal Wiring*, page 49, and Figures 8, 10, 11, and 12 in *Wiring Configurations*.
- 4** Connect the grounding wire to the ground screw located on the exterior of the detector (Figure 6, Item 3.). The detector must be well grounded to earth ground.
- 5** Place and secure the detector's back cover by screwing on the cover and securing it using the secure bolt (Figure 5, Item 15).

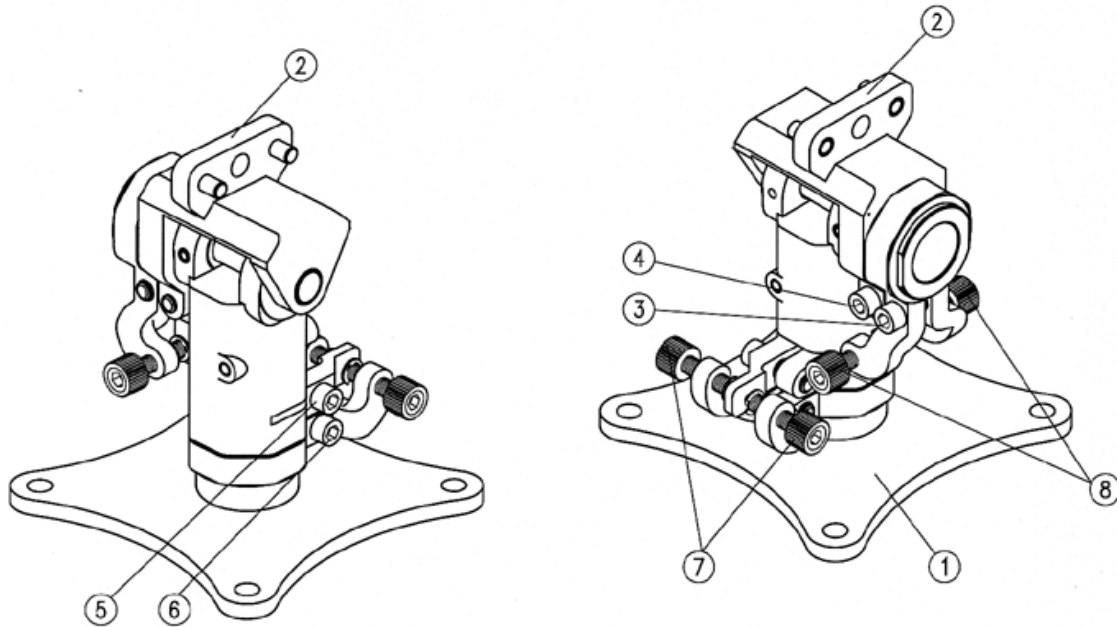

<b>1</b>	Tilt mount holding plate	<b>5</b>	Vertical fine alignment tightening screw
<b>2</b>	Detector/source holding plate	<b>6</b>	Vertical crude alignment tightening screw
<b>3</b>	Horizontal crude alignment tightening screw	<b>7</b>	Vertical fine alignment screw
<b>4</b>	Horizontal fine alignment tightening screw	<b>8</b>	Horizontal fine alignment screw

**Figure 4: Tilt Mount**

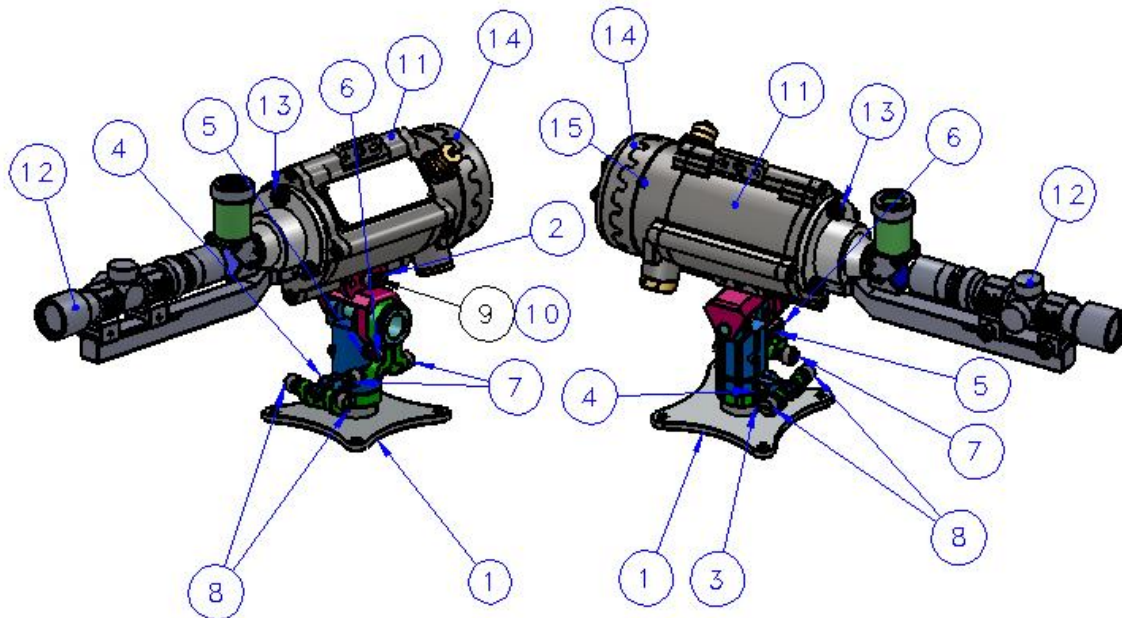

<b>1</b>	Tilt mount holding plate	<b>9</b>	Detector tightening screw
<b>2</b>	Detector/source holding Plate	<b>10</b>	Detector tightening washer
<b>3</b>	Horizontal crude alignment tightening screw	<b>11</b>	Detector
<b>4</b>	Horizontal fine alignment tightening screw	<b>12</b>	Alignment tool
<b>5</b>	Vertical fine alignment tightening screw	<b>13</b>	Alignment tool tightening bolt
<b>6</b>	Vertical crude alignment tightening screw	<b>14</b>	Detector back cover
<b>7</b>	Vertical fine alignment screw	<b>15</b>	Detector back cover secure bolt
<b>8</b>	Horizontal fine alignment screw		

**Figure 5: Detector and Tilt Mount Assembly**

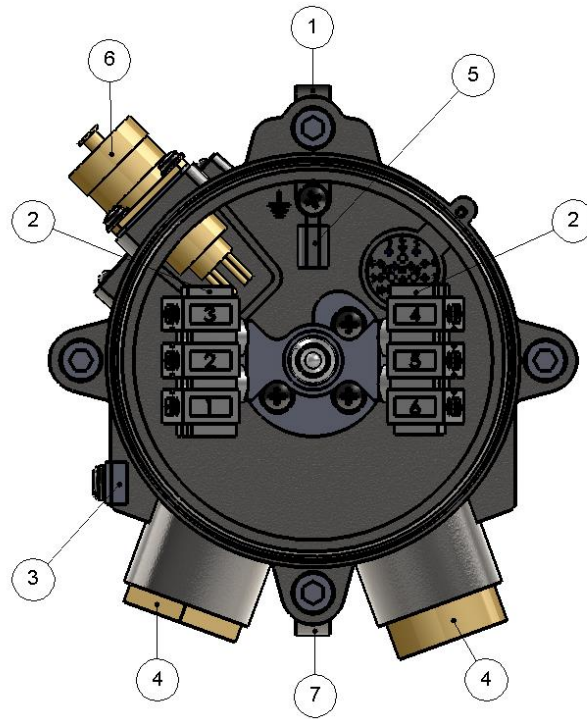

<b>1</b>	Housing	<b>5</b>	Internal earth connection
<b>2</b>	Terminal board	<b>6</b>	Connection to handheld unit
<b>3</b>	Earth terminal	<b>7</b>	Detector holding plate
<b>4</b>	Inlet conduit		

**Figure 6: Detector with Cover Removed**



## 6.8 Detector Terminal Wiring

The detector has 6 wiring terminals.

The following table lists the functions of each electrical terminal of the detector.

**Table 13: Wiring Options**

Terminal No.	Function
1	Power +24VDC
2	Return -24VDC
3	0-20mA In (+)
4	0-20mA Out (-)
5	RS-485 (+)
6	RS-485 (-)

## 6.9 Flash Source Wiring

### 6.9.1 Wiring

■ **To install the wiring:**

- 1 Release the back screw bolt (Figure 5, Item 15,), and open the source back cover (Figure 4, Item 14). The chamber is now exposed.
- 2 Remove the protective plug mounted on the source conduit/cable entry inlet and pull the wires through the source inlet (Figure 7, Item 4,). Use a 3/4" – 14 NPT or M25x1.5 explosion-proof conduit connection/cable gland to assemble the cable/explosion-proof conduit to the detector.
- 3 Connect the wires to the required terminals (Figure 7, Item 2) according to the wiring diagram. See *Terminal Wiring*, page 50 and Figure 11 in Appendix A:.
- 4 Connect the grounding wire to the ground screw located on the exterior of the detector (Figure 7, Item 3). The source must be well grounded to earth ground.
- 5 Place and secure the source unit's back cover by screwing on the cover and securing the back screw bolt.

## 6.9.2 Terminal Wiring

The flash source contains 6 wiring terminals.

**Table 14: Flash Source Wiring Options**

Terminal No.	Function
1	Power +24VDC
2	Return -24VDC
3	Spare
4	Spare
5	RS-485 (+)
6	RS-485 (-)

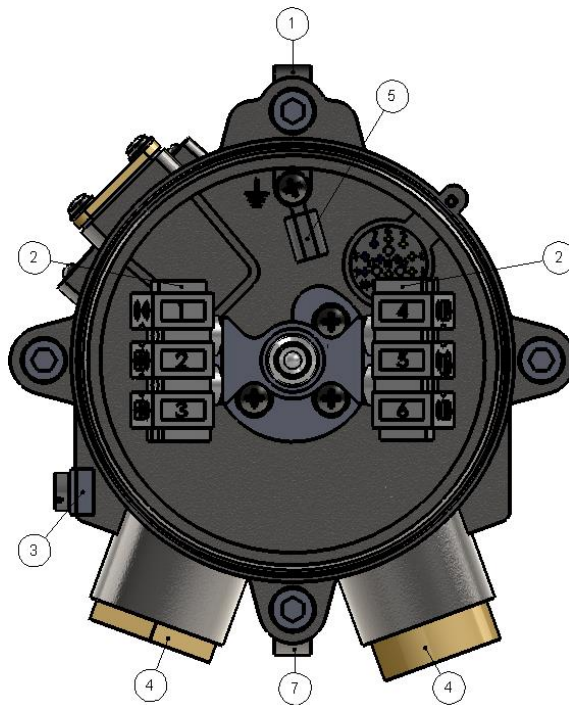

<b>1</b>	Housing	<b>5</b>	Internal earth connection
<b>2</b>	Terminal board	<b>6</b>	N/A
<b>3</b>	Earth terminal	<b>7</b>	Detector holding plate
<b>4</b>	Inlet conduit		

**Figure 7: Source with Cover Removed**

## 7 Operating Instructions

### 7.1 SafEye Operation

Once the system is in place, it automatically monitors for the specified gases, and sends signals to a standard control panel or PC. This section describes the alignment, calibration, and operation of the SafEye System.



**Warning:**

Accurate alignment is essential for proper operation of the SafEye system.

---

### 7.2 Alignment of Unit

The alignment tool is used to perform full alignment.

Perform the alignment procedure in 2 stages: crude alignment and fine adjustment.

The alignment tool includes a periscope that consists of a prism and an ocular that are located vertical to the alignment tool assembly. This allows the user to look into the opposite unit perpendicularly to the one being aligned, when access from the rear of the unit is impossible. For installations where rear access is possible, the periscope is not necessary, and it can be removed by releasing the periscope fastening screw.



**Notes:**

- To ensure proper alignment according to factory calibration, prior to alignment tool installation, verify that the alignment tool and its sight mounting are free of dirt.
  - To ensure optimal alignment, do not attempt to change factory calibration of the alignment tool or its mounting.
- 

■ **To align the unit (see Figure 4):**

- 1** Ensure that the detector and the flash source are installed properly. Installation instructions are described in *Installation Instructions*.
- 2** Remove the front shield using the 2 captive screws.
- 3** Install the alignment tool assembly (Item 12) on the front of the detector/source. Fasten the alignment tool with fastening screws (Item 13).
- 4 Crude Alignment:**
  - a** Use a ¼" Allen screwdriver for all alignment screws.
  - b** Loosen screws 5 and 6.

- c** Approximately aim the source horizontally toward the detector.
  - d** Tighten screw 6.
  - e** Loosen screws 3 and 4.
  - f** Approximately aim the source vertically toward the detector.
  - g** Tighten screw 3.
- 5** Repeat Step 4 for the detector towards the source.
- 6 Fine Alignment:**
- a** Aim the source toward the detector within a horizontal axis using screw 7. Aim the alignment tool cross toward the center of the front window of the detector or source (see Figure 2 and Figure 3, Item 8).
  - a** Tighten screw 5.
  - b** Aim within the vertical axis using screw 8.
  - c** Tighten screw 4.
  - d** Make sure the alignment tool cross is pointing to the center of the detector and source window.
- 7** Repeat Step 6 for the detector alignment.
- 8** Remove the alignment tool and replace the front shield.

## 7.3 Powering up the System



**Caution:**

Prior to any operation or maintenance, check the *Safety Precautions*, page 53.

---

■ **To power up the system:**

- 1** Connect the source and detector to the power source.
- 2** Connect the 4–20mA meter to the detector.
- 3** Power up the system using 18–32VDC.

After 60 seconds, the current meter indicates 4mA.



**Note:**

Perform zero calibration after powering up the system (see *Zero Calibration*, page 54).

---

## 7.4 Safety Precautions

After powering up, the detector requires minimal attention for proper functioning, but the following should be noted:

- Follow the manual instructions, and refer to the drawings and specifications issued by the manufacturer.
- Do not open the detector/source housing while power is connected.
- External devices such as automatic extinguishing systems must be disconnected before performing maintenance tasks required by the warranty.

## 7.5 Signal Verification

Perform signal verification through the host software supplied by SPECTREX (refer to *Manual TM888050*) or by the HART handheld unit (refer to *Manual TM 888030*).

### 7.5.1 Signal Values Limitation

Table 15 describes the maintenance data channels limitation values.

**Table 15: Maintenance Channel Limitation Values**

Channel	Installation Distance			Maintenance
	Short Range	Medium Range	Long Range	
Reference	1V Gain 1	1V Gain 2	1V Gain 5	The minimum signal allowed is 2V at Gain 9
Signal	1V Gain 1	1V Gain 2	1V Gain 5	The minimum signal allowed is 2V at Gain 9
Ratio	0.6–1.4	0.6–1.4	0.6–1.4	0.5–3
NQRat	0.98–1.02			Must be 0.98–1.02
LEL	0 LEL.m			0 LEL. m
Temperature	Up to 77°F/25°C beyond room temperature			Up to 77°F/25°C beyond room temperature
Voltage	32VDC > V > 18VDC			32VDC > V > 18VDC



**Note:**

The installation information refers to the installation distance.

- **Short Range:** The minimum distance, as defined on the model number.
- **Medium Range:** Half of the maximum distance, as defined on the model number.
- **Long Range:** The maximum distance, as defined on the model number.

## 7.6 Zero Calibration

Zero calibration must be performed after any of the following:

- Installation
- Realignment
- Window cleaning
- Any change in detector or source position

Precise alignment must be performed prior to the zero calibration procedure. Perform zero calibration in good weather conditions, with insignificant gas concentrations in the surrounding environment, or indoors.

■ **To perform the zero calibration procedure:**

- 1 Switch from normal to alignment mode indication.
- 2 Switch from alignment to standby mode.
- 3 Switch from standby to zero calibration mode.
- 4 The 0–20mA output should now be at 1mA.
- 5 Wait up to 60 seconds until the mode changes to normal. The detector reading is now set to normal and the 0–20mA output indicates 4mA.

Use the Host HART (refer to *Manual TM888030*), RS-485 (refer to *Manual TM888050*), or move the magnetic mode selector above the magnetic switch (see Figure 8) to switch between each mode.

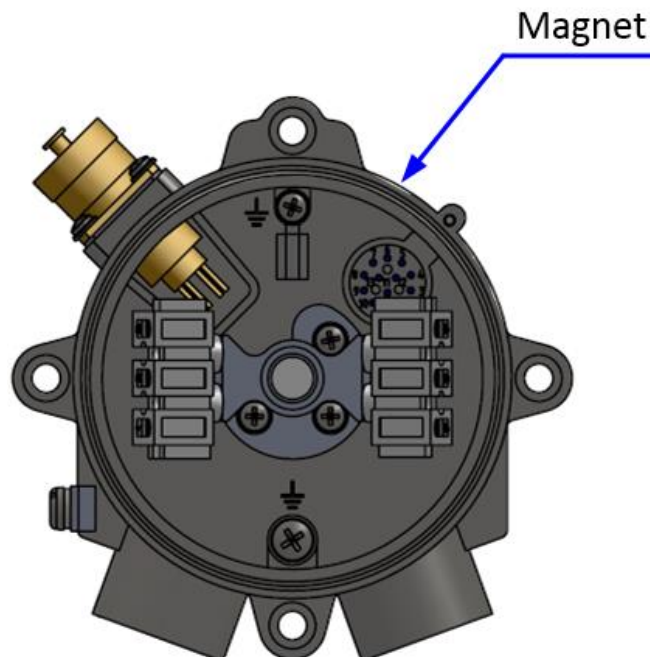

**Figure 8: Magnetic Mode Selector**

## 7.7 Functional Check

The SafEye system has been calibrated at the factory for the user's specific gas or vapor detection requirements. The functional check procedure validates the system's functional operation.

The functional check filter is a convenient operational check used to confirm that a response has not changed from previous readings. The filter is not used for calibration, since it is unnecessary in the procedure, nor does it equate to a particular quantity of gas.

**Caution:**

Disable automatic activation and disconnect any external device that should not be activated during the calibration check

---

**Notes:**

- This functional verification procedure is for a standard 0–20mA output.
  - Prior to starting the functional check, verify that the power to the units is on, and that the current of the 0–20mA channel is stable. Record the reading.
- 

**■ To perform the functional check:**

- 1** Position the functional check filter in front of the SafEye Detector.
- 2** Center the functional check filter's window over the detector's viewing window.
- 3** Wait 20 seconds.
- 4** Read the 0–20mA current. Determine the difference between the reading taken with and without the functional check filter. This difference is the 0–20mA current variance.
- 5** Record the 0–20mA current variance in the maintenance logbook. If the variance is more than a 30% change when compared to the previous check (see delivery form), repeat the alignment.





## 8 Maintenance Instructions

### 8.1 General Maintenance

Only basic periodic maintenance is required to keep the SafEye Quasar 900 at maximum performance and reliability levels. The detector and source units can be maintained with the use of common tools and equipment. The test results should be recorded in a maintenance logbook, together with a copy of the delivery form.

### 8.2 Periodic Maintenance

The optical surfaces of the source and detector viewing windows should be kept as clean as possible, as they are active devices. Perform proper maintenance procedures periodically to allow the SafEye system to retain maximum performance and reliability.



**Note:**

The frequency of cleaning operations depends on the existing environmental conditions and the applications used.

---

- **To perform periodic maintenance:**

- 1 Alignment procedures must be performed each time that the source or the detector unit are opened or moved for any reason.
- 2 The signal verification check corroborates the current signals from the flash source compared to that of previous alignments. This check should be performed every 6–12 months. The signal should be checked according to threshold levels (see *Signal Verification*, page 53).
- 3 Perform a functional check every 6 months (see *Functional Check*, page 55).
- 4 The alignment procedure should be performed only if the signals are below threshold value (see *Signal Verification*, page 53).
- 5 Zero calibration (see *Zero Calibration*, page 54) must be done every time the detector or source is realigned, or the windows are cleaned.

#### 8.2.1 Routine Optical Surface Cleaning

The SafEye system, being an optical device, must be kept as clean as possible. The optical surfaces involved are the source and detector viewing windows.

- **To clean the optical window:**

- 1 Disconnect the power to the SafEye detector and source.
- 2 In places where dust or dirt has accumulated on the optical surface, clean the surface with a small, soft-bristle brush.

- 3** Wash the surfaces thoroughly with water and a mild non-abrasive detergent.
- 4** Thoroughly rinse the glass surface with clean water, ensuring no residue is left behind.
- 5** Dry the glass with a clean, dry, soft cloth.
- 6** Enter the date, name of company, and person who performed the maintenance service into the maintenance logbook.
- 7** Reconnect the power to the SafEye Detector and Source.
- 8** Perform signal verification (see *Signal Verification*, page 53).
- 9** Perform zero calibration (see *Zero Calibration*, page 54).
- 10** Perform a functional check (see *Functional Check*, page 55)

## 8.2.2 Signal Verification

The signal verification check determines the proper operation of the open path. It checks the alignment and cleanliness of the window or any problem in the source or detector. Use the PC Host software to measure the signal verification.

Refer to *Manual TM 888050* or use the IS handheld unit.

## 8.2.3 Functional Check of Unit

The SafEye Quasar has been calibrated at the factory according to the user's specific gas or vapor detection requirements. Use the check filters included in the commissioning kit according to the corresponding calibrating gas to validate correct installation. Refer to *Functional Check*, page 55, for instructions.



### **Caution:**

Disable automatic activation and disconnect any external device that should not be activated during the calibration check.

---

## 9 Troubleshooting

**Table 16: Troubleshooting**

<b>Fault Indication</b>	<b>Problem</b>	<b>Cause</b>	<b>Solution</b>
Host status: "C" 0-20= 3mA	"Maintenance call" status or R and S are below 2V DC at Gain 9 LED - Green blinking 1Hz.	Poor alignment	Perform alignment
		Dirt on the window	Clean the window
		Poor light source	Replace the light source
		Detector fault	Replace/repair detector
Host status: "O" or "I" 0-20= 2mA LED - Yellow blinking	The detector is in constant obscuration mode.	Poor alignment	Perform alignment
		Dirt on the window	Clean the window
		Poor light source	Replace the light source
		Detector fault	Replace/repair detector
	The detector is in constant saturation mode.	Installation distance is lower than allowed	Use different model
		Detector fault	Replace/repair Detector
Host status: "M" 0-20= 2.5mA LED - Yellow blinking	The detector is in constant misalignment mode.	Poor alignment	Perform alignment
		Detector fault	Replace/repair Detector
Host status: "V" 0-20= 1mA LED - Yellow blinking	The detector is at "V" fault	Low/High input voltage	Check the power supply and installation
		Detector fault	Replace/repair detector
Host status: "F" 0-20= 1mA LED - Yellow blinking	Internal Fault	Internal Fault	Replace the detector

Fault Indication	Problem	Cause	Solution
	NQRat below the permitted limit	Gas in the path	Make sure that the path is clean and the weather conditions are good
	NQRat above the permitted limit	Poor alignment	Perform alignment
	Ratio1 and Ratio2 out of the limit	Poor alignment	Perform alignment
		Dirt on the window	Clean the window
		Detector fault	Replace/repair detector
Yellow LED blinking at the source	Source Fault	Low/high input voltage	Check the power supply and installation
		Internal Fault	Replace the source

## Appendix A: Wiring Configurations

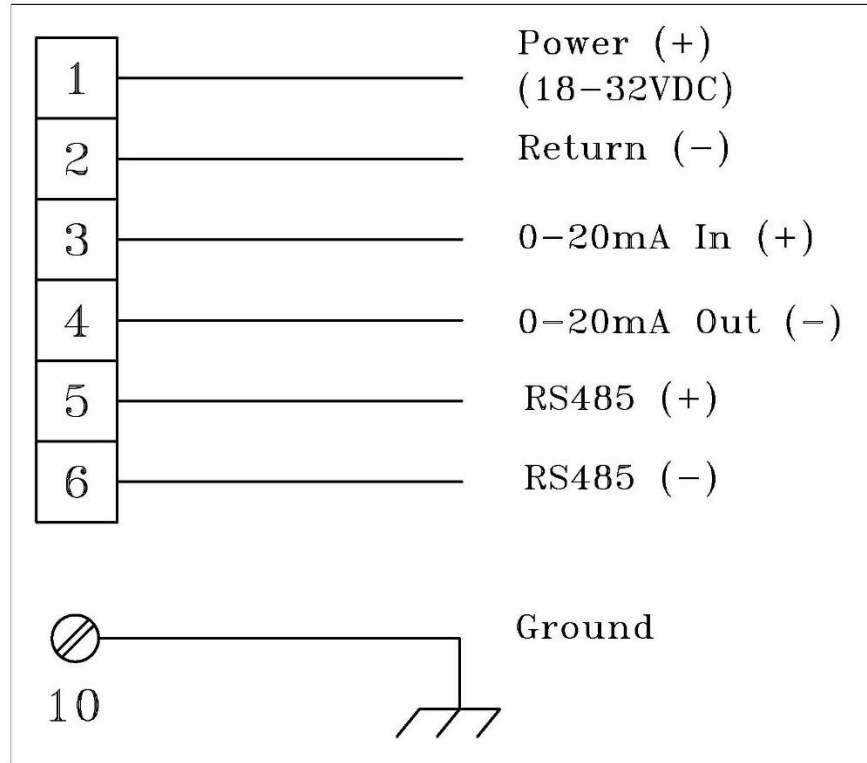

**Figure 9: Detector Wiring Terminal**

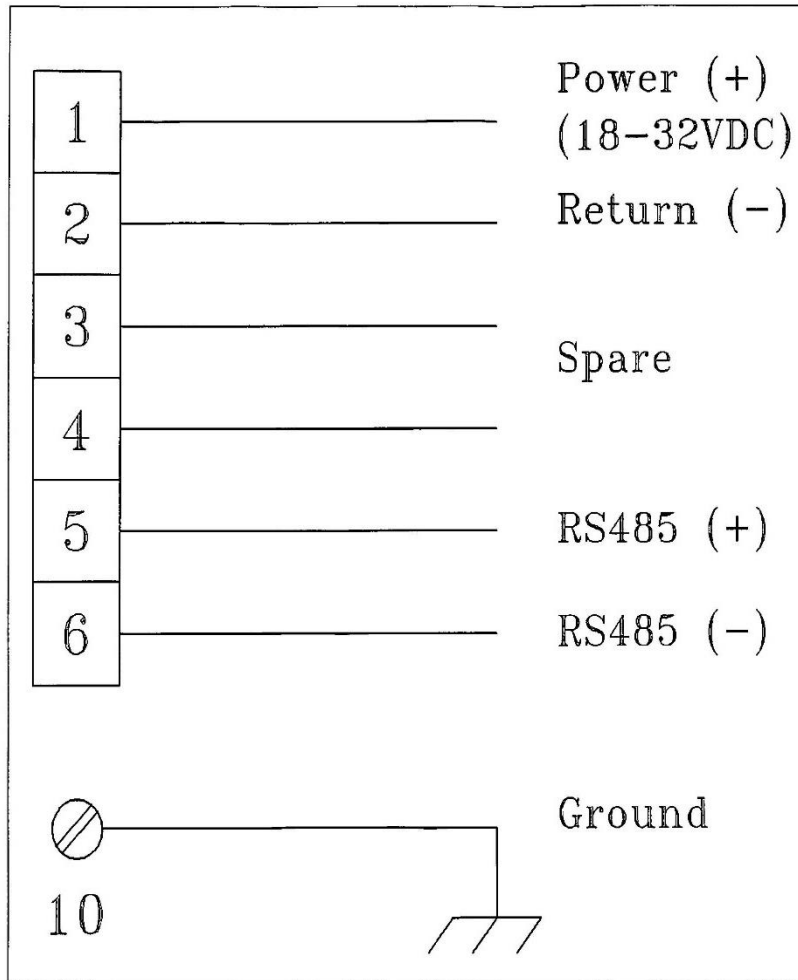

**Figure 10: Source Wiring Terminal**

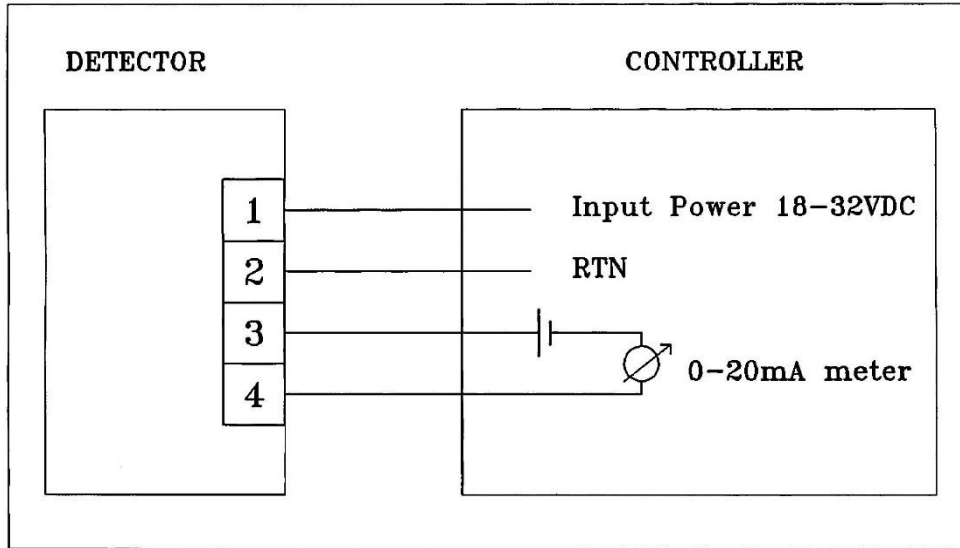

**Figure 11: 0-20mA Sink 4-Wire**

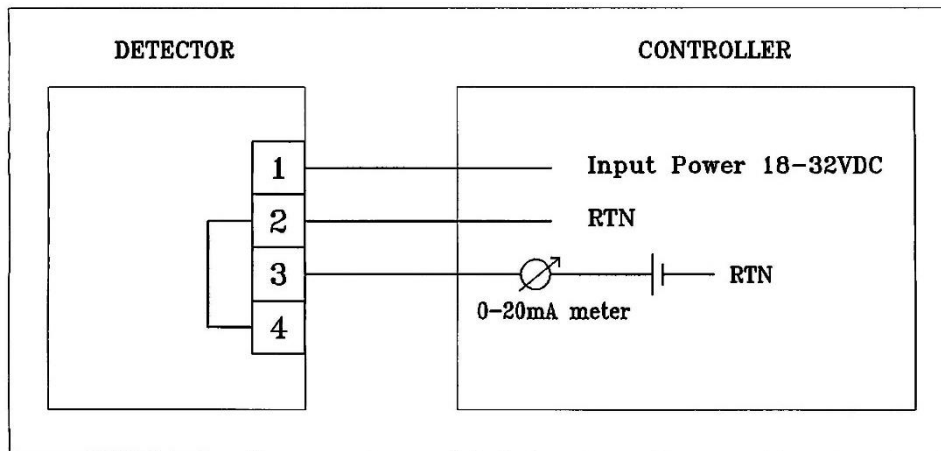

**Figure 12: 0-20mA Non-Isolated Sink 3-Wire**

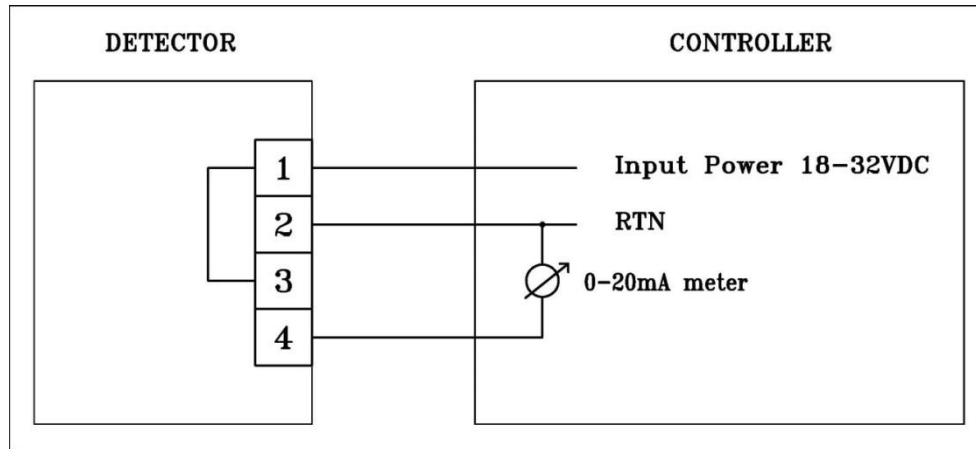

Figure 13: 0-20mA Source 3-Wire

## A.1 RS-485 Communication Network

By using the RS-485 network capability of the SafEye Quasar 900 Detector and additional software, it is possible to connect up to 32 detectors in an addressable system with 4 wires only (2 for power and 2 for communication). Using repeaters, the number of detectors can be much larger (32 detectors for each repeater): up to 247 on the same 4 wires. When using the RS-485 network, it is possible to read each detector status (FAULT, WARNING, and ALARM) individually.

For more details, contact SPECTREX.

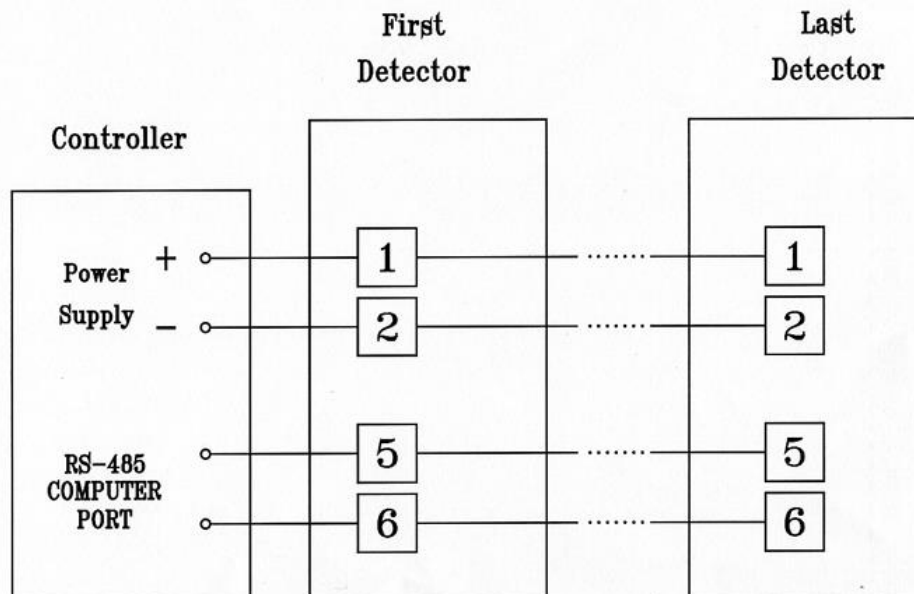

Figure 14: RS-485 Networking for Wiring Option 3



## Appendix B: Accessories

### B.1 Tilt Mount

The tilt mounting brackets (P/N 888270) allow for accurate alignment of the detector/source for proper operation of the open path. The brackets give crude alignment of  $\pm 60^\circ$ , and a fine alignment of  $\pm 10^\circ$ .

### B.2 Pole Mount (U-Bolt 4-5 inch)

The U-bolt mount (P/N 799225) is available to facilitate 5 inch pipe mounting.

### B.3 Pole Mount (U-Bolt 2-3 inch)

The U-bolt mount (P/N 888140) is available to facilitate 2-3 inch pipe mounting.

### B.4 Wall Mount

The Wall Mount (P/N 888269) is available to facilitate wall mounting.

### B.5 Commissioning Kit

The commissioning/alignment kit unit (P/N 888247) is required for commissioning and future maintenance checks. Only 1 kit is required per site.

There are 3 commissioning kit options:

- 888247-1 for methane calibration
- 888247-2 for propane calibration
- 888247-3 for ethylene calibration

The kit includes an alignment tool (P/N 888210), a magnetic mode selector (P/N 790285), 2 functional check filters (P/N 888260-1÷6) for system installation and periodical functional testing, as well as socket keys for access to units.

**Table 17: Check Filters**

Check Filter Part Number	Gas Concentration
888260-1	110-270LEL.m propane
888260-2	310-490LEL.m propane
888260-3	150-250LEL.m methane
888260-4	300-480LEL.m methane
888260-5	180-320LEL.m ethylene
888260-3 or 888260-6	490-760LEL.m ethylene

## **B.6 HART Handheld Diagnostic Unit**

The HART handheld diagnostic unit (P/N 888810) is fitted with a harness to the quick-plug connection, providing an easy, economical connection. The HART handheld unit provides verification, status, and instructions for correcting the detector's parameters. The unit is IS-approved, with a special harness to suit the detector, and a host for maintenance and commissioning.

## **B.7 HART Handheld Harness Kit**

A quick plug connection with a harness (P/N 888815) is connected on one side to a standard HART handheld unit. This includes the SPECTREX host software that can be uploaded to an existing handheld unit. The kit does not include the handheld unit.

Refer to *Manual TM888030* for more information.

## **B.8 USB/RS-485 Harness Converter Kit**

The USB RS-485 Harness Kit with RS-485/USB converter (P/N 794079), together with SPECTREX host software, enables the user to connect to any available PC or laptop to reconfigure settings or perform diagnostics on the Quasar 900 Gas Detector.

Refer to *Manual TM888050* for programming instructions.

## **B.9 Protective Cover**

The protective cover (P/N 888263) is designed to protect the detector from the heat of the sun.

## Appendix C: SIL-2 Features

This appendix details the special conditions for compliance with the requirements of EN 61508 for SIL-2.

The SafEye Quasar 900 IR Open-Path Gas Detector can be used in low and high demand mode applications - see *IEC 61508-4:2010, Chapter 3.5.16*.

### Safety Relevant Parameters

Type:	B
Structure:	1001
HFT:	0
Main time to repair:	72hr
Ambient temperature:	max 149°F/65°C
Proof-Test-Interval:	52 weeks

$$\lambda_S = 2056.1 \cdot \text{fit}$$

$$\lambda_D = 1976.1 \cdot \text{fit}$$

$$\lambda_{DU} = 114.8 \cdot \text{fit}$$

$$\lambda_{SD} = 1933.4 \cdot \text{fit}$$

$$\lambda_{DD} = 1861.4 \cdot \text{fit}$$

$$\text{SFF} = 97\%$$

$$\text{DC} = 94\%$$

$$\text{PFD}_{\text{avg}} = 6.45 \times 10^{-4}$$

$$\text{PFD\%}_{\text{SIL2}} = 6.4\%$$

$$\text{PFH} = 1.15 \times 10^{-7} \text{ 1/h}$$

$$\text{PFH\%}_{\text{SIL2}} = 11.5\%$$

### General Conditions for Safe Use

- The SafEye Quasar 900 IR Open-Path Gas Detector should consist only of the approved hardware and software modules.
- Take note of the application advice and limitations listed in this manual. The regional and national regulations should be considered when performing calibration/maintenance tasks.
- The 24V power supply must fulfill the requirements for SELV/PELV of EN 60950.

- Do not use the HART and RS-485 interfaces for transmission of safety- related data.
- According to SIL-2 requirements, the alert conditions can be implemented by an alert signal via the 20mA current loop.
- After installation and configuration, the setup parameters must be verified and the function of the SafEye Quasar 900 IR Open-Path Gas Detector must be checked completely.
- The alarm conditions of the transmitter must be checked periodically together with standard gas calibration checks. The SafEye Quasar 900 IR Open-Path Gas Detector must be switched off and on.
- The connected controller must monitor the 0–20mA signal current for values below 4mA and above 20mA.
- Defects found in the detector must be repaired within 72 hours.



# Technical Support

For technical assistance or support, contact:



6021 Innovation Blvd,  
Shakopee, MN 55379 ,  
USA

Phone: +1 (973) 239 8398

Fax: +1 (973) 239 7614

Email: [spectrex.csc.rmtna@emerson.com](mailto:spectrex.csc.rmtna@emerson.com)

Website: [www.spectrex.net](http://www.spectrex.net)