



®

# enose<sup>®</sup> DUST/AD GAS TRANSMITTER

*enose<sup>®</sup> Technology*



## *INSTALLATION AND OPERATING INSTRUCTIONS*

Printed in Italy  
January 2014  
Rev.4.7.0

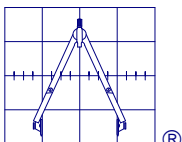

OGGIONI S.a.s. Via Lavoratori Autobianchi, 1 20832 Desio (MB) Italy  
Tel. +39 0362 629135 Fax.+39 0362 622531 e-mail: [info@oggionisas.com](mailto:info@oggionisas.com)  
On-line support [techsupport@oggionisas.com](mailto:techsupport@oggionisas.com) - web: [www.oggionisas.com](http://www.oggionisas.com)



## Copyright

The technical documentation in this manual is a OGGIONI s.a.s. Publication and the use thereof are reserved for users of the system. Complete or partial reproduction for any other use other than as support material for users of the system is forbidden without specific, written authorisation from OGGIONI s.a.s.

## Registered Trademark

OGGIONI and the logo OGGIONI s.a.s. enose® are registered trademarks of OGGIONI s.a.s.

Oggioni reserves the right to change published specifications and designs without prior notice!

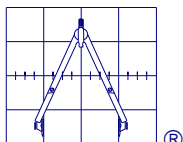

OGGIONI S.a.s. Via Lavoratori Autobianchi, 1 20832 DESIO (MB) Italy  
Tel. +39 0362 629135 Fax.+39 0362 622531 e-mail: [info@oggionisas.com](mailto:info@oggionisas.com)  
On-line support [techsupport@oggionisas.com](mailto:techsupport@oggionisas.com) - web: [www.oggionisas.com](http://www.oggionisas.com)



## **WARRANTY STATEMENT**

### **Warranty**

Oggioni S.a.s. warrants that all items delivered under this agreement will be free from defects in material and workmanship, conform to applicable specifications, and, to the extent that detailed designs have not been furnished by the buyer, will be free from design defects. Oggioni S.a.s. shall not be liable for the goods being fit for a particular purpose. The above warranty is given by Oggioni S.a.s. subject to the following conditions:

Oggioni S.a.s. shall not be liable in respect of any defect in the goods arising from any design or specification supplied by the buyer;

Oggioni S.a.s. shall not be liable under the above warranty if the total price for the goods has not been paid by the time period specified in charter 6 of the present conditions of sales.

The above warranty does not extend to parts, materials or equipments manufactured by or on behalf of the buyer unless such warranty is given by the manufacturer to Oggioni S.a.s.

If so required by Oggioni S.a.s. the Products will be returned to Oggioni S.a.s. by the buyer at the buyer's risk and expense;

This warranty does not cover defects in or damage to the products which are due to improper installation or maintenance, misuse, neglect or any cause other than ordinary commercial application. Any claim by the buyer which is based on any defect in the quality or condition of the goods or their failure to correspond with specifications shall be notified to Oggioni S.a.s. within 24 months from the date of delivery, unless otherwise specified by Oggioni S.a.s. in writing.

Where any valid claim in respect of any goods which is based on any defect in the quality or conditions of the goods or their failure to meet specifications is notified to Oggioni S.a.s. in accordance with this conditions, Oggioni S.a.s. shall be entitled at Oggioni S.a.s.' sole discretion to either replace the goods free of charge or repair the goods. If Oggioni S.a.s. is neither ready nor able to either repair or replace the goods the buyer shall be entitled at the buyer's sole discretion to claim for a reduction of price or the cancellation of the contract.

### **Limitation of Liability**

The warranty is in substitution for and shall replace all conditions and warranties on the part of Oggioni S.a.s. implied by statute or common law or otherwise all of which are expressly excluded (insofar as they may be excluded by law) and Oggioni S.a.s. shall not be liable whether in contract, tort or otherwise in respect of defects or in damage to the products or for any injury loss or damage of whatever kind attributable to such defects or damage.

Note that: it is the buyer's responsibility to satisfy itself that the products are suitable for its requirements and Oggioni S.a.s. does not profess to have any skill or judgement in relation to the particular needs of the buyer. The buyer shall be deemed to have full knowledge of the nature and properties of and shall carry out its own testing of the accuracy and performance of the products.

If Oggioni S.a.s. is found liable for any loss or damage suffered by the buyer that liability shall be limited to the price of the products hereunder and in no event shall Oggioni S.a.s. be liable for any loss of profit or any other commercial loss including but not limited to special incidental consequential or other loss or damage.

Although Oggioni S.a.s. will use its best endeavours to ensure that any figure published by Oggioni S.a.s. relating to the performance of the product are accurate, Oggioni S.a.s. does not warrant the accuracy of any published performance figure.

When ordering goods to Oggioni S.a.s. the buyer undertake burden to be in knowledge of all legal limitations and applications and security norms about use of supplied goods. It is therefore excluded any responsibility of Oggioni S.a.s. about use, wrong use, impossibility of use of supplied devices; compensation requests for direct or indirect damages caused by use, wrong use, impossibility of use of supplied devices for whatever reason will thereby not be possible.

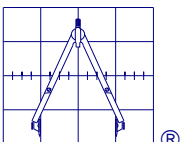

**OGGIONI S.a.s.** Via Lavoratori Autobianchi, 1 20832 DESIO (MB) Italy  
Tel. +39 0362 629135 Fax.+39 0362 622531 e-mail: [info@oggionisas.com](mailto:info@oggionisas.com)  
On-line support [techsupport@oggionisas.com](mailto:techsupport@oggionisas.com) - web: [www.oggionisas.com](http://www.oggionisas.com)



## **WARNINGS and CAUTIONS**



Before using the enose<sup>®</sup> transmitters make sure you have read and understood the operating and installation instructions in the present manual.

- make sure the cover is properly fastened before operating the transmitter
- do not paint the sensor head or the detector assembly
- at start up calibrate the transmitter and then at least every 90 days.
- do not expose the transmitter to electrical and/or mechanical shock.
- make sure the air inlet to the sensor through the sinter filter or the wire mesh are clean of dirt and/or condense and keep away from accidental painting.
- any repairing to the enose transmitters shall be executed by Oggioni authorised personnel only. Non Oggioni repair attempts will void the warranty.

## **STORAGE**

For storage we suggest to store in a clean and dry area and within the temperature range quoted in the Specifications (See chapter 2.3 on page 9).

When prolonged storage is known, instruments should be sealed, together with a desiccant, into plastic bags and double wrapped for protection.

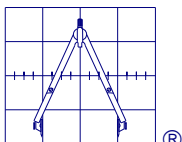

OGGIONI S.a.s. Via Lavoratori Autobianchi, 1 20832 DESIO (MB) Italy  
Tel. +39 0362 629135 Fax.+39 0362 622531 e-mail: [info@oggionisas.com](mailto:info@oggionisas.com)  
On-line support [techsupport@oggionisas.com](mailto:techsupport@oggionisas.com) - web: [www.oggionisas.com](http://www.oggionisas.com)





## EC Declaration of Conformity

We, Oggioni s.a.s,  
Via G. da Besana, 11  
20045 Besana B. (Mi)  
Italy  
declare under our sole  
responsibility that  
the mentioned product  
is in accordance  
with the applicable  
european directive and  
to the listed harmonized  
standards or  
normative  
documents.  
Where applicable,  
a competent body  
has been released  
the relevant EC Type  
Examination

This Declaration of Conformity is relevant to the following products

### Gas detector, DUST series

relevant european directive **94/9/EC**  
**2004/108/EC**

<b>EN-60079-0:2006</b>	Electrical apparatus for explosive gas atmospheres: General requirement
<b>EN 60079-29-1: 2007</b>	Explosive atmospheres. Gas detectors. Performance requirement
<b>EN-50270 :2006</b>	Electromagnetic Compatibility - Electrical apparatus for detection and measurement of combustible gases, toxic gases or oxigen

Type of protection: **II 3G**  
**Ex nA II T6 IP65**

Notification of Quality System according to annex VII of 94/9/EC directive  
no. 03 ATEX 4539Q issued by Notified Body Nemko AS – CE0470

Signature of manufacturer

General Director

Managing Director

Date: 15/02/2010

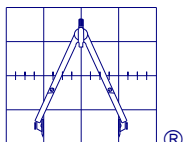

OGGIONI S.a.s. Via Lavoratori Autobianchi, 1 20832 DESIO (MB) Italy  
Tel. +39 0362 629135 Fax.+39 0362 622531 e-mail: [info@oggionisas.com](mailto:info@oggionisas.com)  
On-line support [techsupport@oggionisas.com](mailto:techsupport@oggionisas.com) - web: [www.oggionisas.com](http://www.oggionisas.com)



## Table of Contents

WARRANTY STATEMENT .....	3
WARNINGS and CAUTIONS .....	4
STORAGE .....	4
I INTRODUCTION .....	7
1.1 General Description .....	7
1.2 Features .....	8
1.3 Typical Application.....	8
II SPECIFICATION.....	8
2.1 General specification.....	8
2.2 Electrical Specification .....	9
2.3 Environmental Specification .....	9
2.4 Mechanical Specification .....	9
2.5 Detector Configurations .....	10
2.6 Outline drawing.....	10
2.6.1 Outline drawing standard DUST/AD .....	10
2.6.2 Outline drawing DUST/AD/.../ID version .....	11
III INSTALLATION.....	12
3.1 Sensor Location Guidelines .....	12
3.2 Sensor Poisoning – installation precautions.....	12
3.3 Generic wiring guidelines .....	13
3.4 Cable connection guidelines.....	13
3.5 Final inspection and Start Up .....	16
3.6 Fault conditions and Actions.....	16
IV BUMP TEST.....	17
V CALIBRATION.....	17
5.1 ZERO Calibration .....	18
5.2 SPAN Calibration.....	18
5.2.1 Span calibration with relay outputs (CCS).....	18
5.2.2 Span calibration using an ampermeter .....	19
5.2.3 Span calibration for Oxygen detectors using an ampermeter.....	20
VI MAINTENANCE .....	22
VII MODBUS RTU Serial Interface.....	23
7.1 Introduction .....	23
7.2 Modbus read command .....	23
7.3 Memory map .....	23
VIII ACCESSORIES .....	24

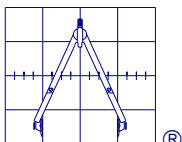

OGGIONI S.a.s. Via Laboratori Autobianchi, 1 20832 DESIO (MB) Italy  
 Tel. +39 0362 629135 Fax.+39 0362 622531 e-mail: [info@oggionisas.com](mailto:info@oggionisas.com)  
 On-line support [techsupport@oggionisas.com](mailto:techsupport@oggionisas.com) - web: [www.oggionisas.com](http://www.oggionisas.com)



## **I INTRODUCTION**

### **1.1 General Description**

The enose<sup>®</sup> AD transmitters are designed to measure concentrations of combustible gases in the range of 0-100% Lower Explosive Level (LEL) or concentrations of toxic gases, in ppm range, in an atmosphere generally consisting of air.

A modular design of the transmitters allows the usage of sensors in various technologies: IR, Pellistor, Electrochemical Cell and MOS.

Made in SMT technology, the enose<sup>®</sup> Transmitter is extremely compact and sealed in the detector's head. It may be used either as an autonomous detecting device featuring electrical controls right next to the sensor, or it may be connected to remote data monitoring systems.

#### enose<sup>®</sup> GM1 Sensor Head

The sensor head is a self contained microprocessor controlled device, designed with a non-volatile memory, allowing a non intrusive calibration, easily performed with a magnetic tool by one person only. The air sample to be analysed enters the head's measuring chamber, where the sensor is located, by convection and diffusion through a flame arrester sintered stainless steel filter or wire mesh screened opening.



Fig. 1.1.1 DUST AD

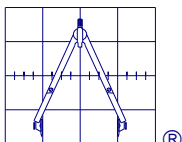

OGGIONI S.a.s. Via Lavoratori Autobianchi, 1 20832 DESIO (MB) Italy  
Tel. +39 0362 629135 Fax.+39 0362 622531 e-mail: [info@oggionisas.com](mailto:info@oggionisas.com)  
On-line support [techsupport@oggionisas.com](mailto:techsupport@oggionisas.com) - web: [www.oggionisas.com](http://www.oggionisas.com)



## 1.2 Features

The DUST/AD enose<sup>®</sup> gas transmitters are microprocessor based devices featuring a 4-20 mA output, three voltage free relay contacts and an RS-485 digital interface.

Optional versions are available provided with and LCD Display 8x2 characters.

The transmitters are fully programmable and easy to maintain being designed for a Non Intrusive "One Person" calibration.

Small size

Low Power consumption

Certificate ATEX II 2G EEx-d IIC T6

## 1.3 Typical Application

Ideal for detect combustibile gas and solvents

Strong poison resistant properties

Built-in or separate sensor transmitter

Built-in relays enable full stand-alone capability

DUST/AD sensors are made in compliance with European standard EN54 and following ATEX directives.

## II SPECIFICATION

### 2.1 General specification

Sensor Technologies	IR Catalytic Electrochemical MOS
IP Rating	IP65
Location	NON hazardous area
Short-term repeatability	±2% FSD 60 min.
Long-term repeatability	±5% FSD 3 months
Accuracy	±5% FSD

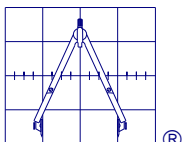

OGGIONI S.a.s. Via Laboratori Autobianchi, 1 20832 DESIO (MB) Italy  
 Tel. +39 0362 629135 Fax.+39 0362 622531 e-mail: [info@oggionisas.com](mailto:info@oggionisas.com)  
 On-line support [techsupport@oggionisas.com](mailto:techsupport@oggionisas.com) - web: [www.oggionisas.com](http://www.oggionisas.com)





## 2.2 Electrical Specification

Supply Voltage	12-30 Vdc
Power consumption	<b>IR Combustible sensors</b> 140mA @ 13.5V; 80mA @ 24V <b>Catalytic combustibile sensors</b> H.Q. Sensor: 140mA @ 13.5V; 110mA @ 24V Standard Sensor: 75mA @ 13.5V; 55mA @ 24V <b>Oxygen/Toxic gas sensors:</b> 60mA @ 13.5V; 40mA @ 24V <b>MOS sensors:</b> 100mA @ 13.5V; 70mA @ 24V Relays Configuration: +20mA @ 13.5V; +10mA @ 24V each energized relay, for a maximum of 3 relays.
Supply fuse	500 mA
Signal fuse	63 mA
Analogue output	4-20 mA
Load	0-300 ohms
Cable Type	4-20mA: 3 conductor shielded cable Relays: 2 conductor
Relays	2 Low level/High level alarms relays 1 Fault relay Programmable for normally energised/de-energised, latching/non-latching Max. contact resistance 150 mΩ Max. switching voltage 100Vdc Max. switching current 1A

## 2.3 Environmental Specification

EMC susceptibility	10V/m
Storage temperature	-40 to 85 °C
Operating temperature	-20 to 70 °C - excluded electrochemical cells -20 to 50°C - for electrochemical cells only
Humidity range	90% R.H. n.c.
Pressure range	80-120kPa – for electrochemical cells only

## 2.4 Mechanical Specification

Overall dimensions	140x76x54 mm (Aluminium Housing)
Weight	0.4 Kg
Mounting	2x6 mm holes
Termination	Screw terminal block for wires up to 2,5mm <sup>2</sup>
Junction box attachment	3/4" Conical Thread UNI 6125

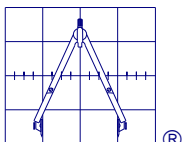

OGGIONI S.a.s. Via Lavoratori Autobianchi, 1 20832 DESIO (MB) Italy  
 Tel. +39 0362 629135 Fax.+39 0362 622531 e-mail: [info@oggionisas.com](mailto:info@oggionisas.com)  
 On-line support [techsupport@oggionisas.com](mailto:techsupport@oggionisas.com) - web: [www.oggionisas.com](http://www.oggionisas.com)



## 2.5 Detector Configurations

The DUST detectors may have various output configurations according to the application requests. In brief, the coding below, groups together the various options.

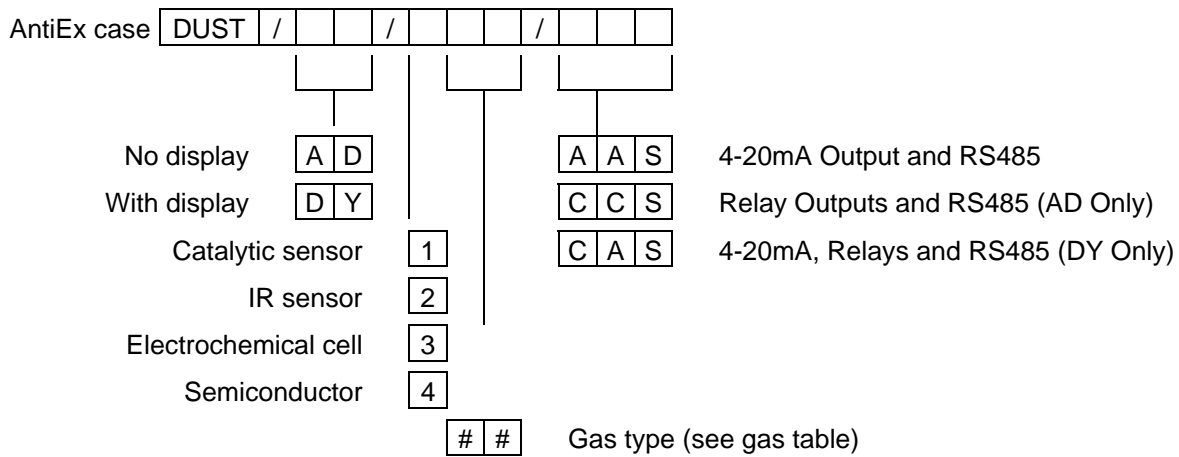

## 2.6 Outline drawing

### 2.6.1 Outline drawing standard DUST/AD

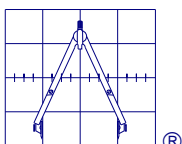
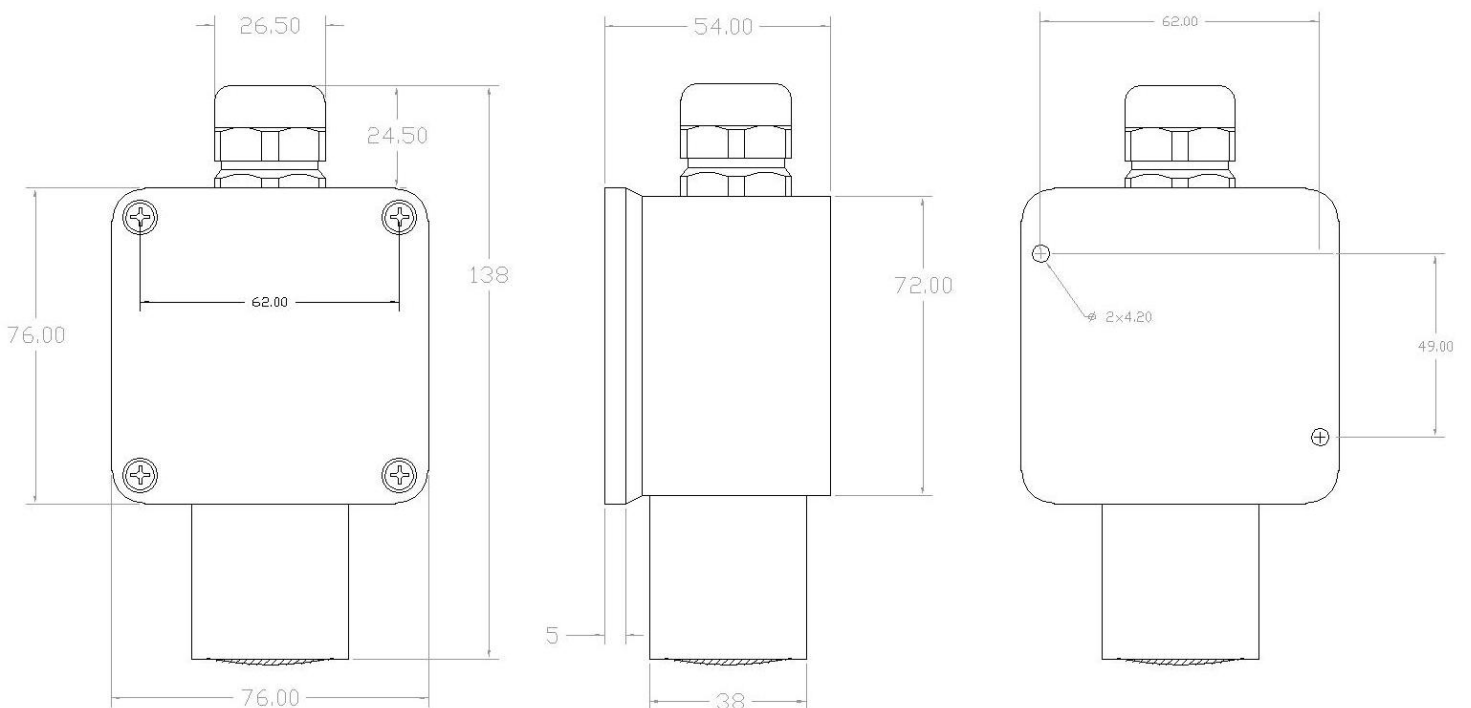

OGGIONI S.p.A. Via Laboratori Autobianchi, 1 20832 DESIO (MB) Italy  
 Tel. +39 0362 629135 Fax.+39 0362 622531 e-mail: [info@oggionisas.com](mailto:info@oggionisas.com)  
 On-line support [techsupport@oggionisas.com](mailto:techsupport@oggionisas.com) - web: [www.oggionisas.com](http://www.oggionisas.com)



### 2.6.2 Outline drawing DUST/AD/.../ID version

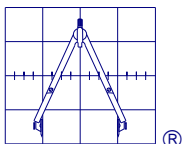
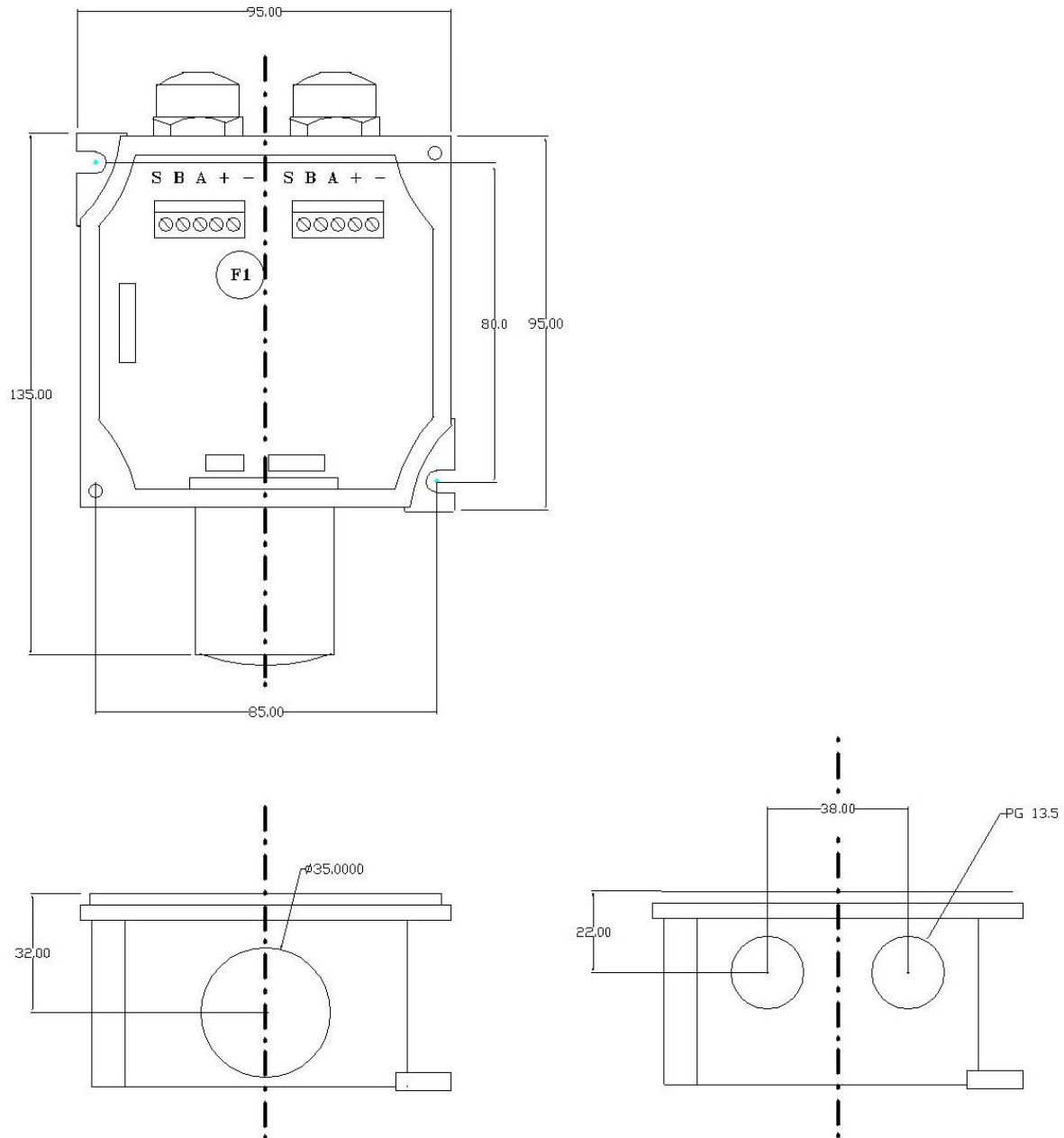

OGGIONI S.p.A. Via Lavoratori Autobianchi, 1 20832 DESIO (MB) Italy  
Tel. +39 0362 629135 Fax.+39 0362 622531 e-mail: [info@oggionisas.com](mailto:info@oggionisas.com)  
On-line support [techsupport@oggionisas.com](mailto:techsupport@oggionisas.com) - web: [www.oggionisas.com](http://www.oggionisas.com)



## **III INSTALLATION**



Installation must be carried out by well skilled and competent personnel only.

Site the sensors to facilitate recalibration and maintenance routine.

Always mount the sensors vertically with the detection head facing downwards and the cable entry on top.

The DUST sensors, must be installed in accordance with the certification documents and the relevant regulations of the country concerned.

### **3.1 Sensor Location Guidelines**

The first factor to consider when deciding where to position the sensors is the type of gas that has to be detected.

Normally, for gases with a density less than the air (hydrogen, methane, etc.), the sensors are uniformly distributed at about 30cms from the highest point of the ceiling, because these gases are easily defused in the air.

It is as well to avoid places where there are air currents or where the air is likely to be very still because of certain irregularities of the ceiling e.g. beams etc. which stop the gas moving around freely.

For gases with higher density than the air the sensors should be placed near the floor and in proximity to possible air vents.

Particular points such airspaces, junction boxes, manholes, and weigh-bridges should always be controlled by a sensor.

For gases with a specific weight similar to the air one or for toxic substances in low concentration it is a good general rule to distribute the sensor at different levels to heighten the chances of intercepting an eventual leak.

Always have the gas sensor head pointing downwards so that the gas inlet is protected from water and accumulation of dust and/or dirt. Site the sensors to facilitate recalibration and maintenance routine.

### **3.2 Sensor Poisoning – installation precautions**

There are certain substances that if present in the atmosphere to be analysed can alter considerably the response of the sensor. These in the main are chemical poisons.

The more important poisons are:

Halides (Compounds containing fluorine, chlorine, bromine and iodine).

Glycol Sulphur (Compounds which polymerise on the bead).

Heavy Metals (Tetraethyl lead).

If the presence of these substances is to be expected on the site in which the sensors have been installed, it is advisable to verify frequently the sensitivity of the detectors using calibration gas.

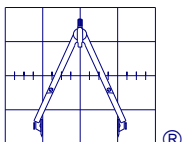

OGGIONI S.a.s. Via Laboratori Autobianchi, 1 20832 DESIO (MB) Italy  
Tel. +39 0362 629135 Fax.+39 0362 622531 e-mail: [info@oggionisas.com](mailto:info@oggionisas.com)  
On-line support [techsupport@oggionisas.com](mailto:techsupport@oggionisas.com) - web: [www.oggionisas.com](http://www.oggionisas.com)



### 3.3 Generic wiring guidelines

The use of shielded cables is recommended.

Should more than one strand of wire be used in the wiring be sure that the cable screen is continuous and that the conductors are soldered at the joints.

The cable screen must be connected to safety earth in safe area.

Furthermore it must be remembered that the protective shielding must be earthed only on the control unit or power supply side and should never be connected to the detector.

The use of terminal leads is recommended, otherwise the joints on the power cable must be clamped with flat tab connectors or soldered.

It is recommended to avoid detectors connection to the same power source. Inductive loads could generate ‘noises’ on the power supply to the system.

In any case the usage of auxiliary winding is recommended on the main power transformer, to supply suppression devices, actuators, sounders or other devices.

Complete all cable insulation testing before connecting the cable at either end.

When all wiring has been completed and tested, the system may be powered-up.

The following table gives a guide about the wire section and the distance correspondence.

Distance	Section	Section
Km.	AWG	mm <sup>2</sup>
<1	17	1
1.5	15	1.6
2.5	13	2.5

Recommended cable type FG7OH2R or similar.

### 3.4 Cable connection guidelines

The DUST/AD detectors require an interconnecting cable having up to ten conductors, that will be connected, according to the DUST version as follows. In the following there are presented all versions of DUST configurations with their terminal poles.

#### a) 4-20mA with serial line RS485 version / .. / AD / AAS

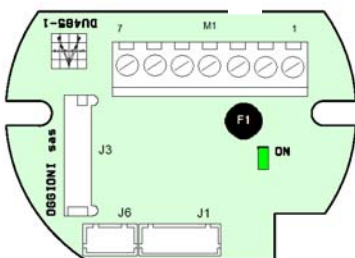

Terminal pins	Signal	Description
1	(-)	Negative
2	+12÷24VDC	Power supply
3	4-20mA	Analogue output
4	(-)	Negative
5	A	A RS-485
6	B	B RS-485
7	Screen	Cable Screen

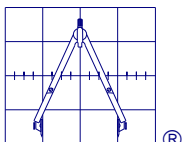

OGGIONI S.a.s. Via Laboratori Autobianchi, 1 20832 DESIO (MB) Italy  
 Tel. +39 0362 629135 Fax.+39 0362 622531 e-mail: [info@oggionisas.com](mailto:info@oggionisas.com)  
 On-line support [techsupport@oggionisas.com](mailto:techsupport@oggionisas.com) - web: [www.oggionisas.com](http://www.oggionisas.com)



Atex Certified

**b) RS485 serial line only DUST / AD / .. / ID**

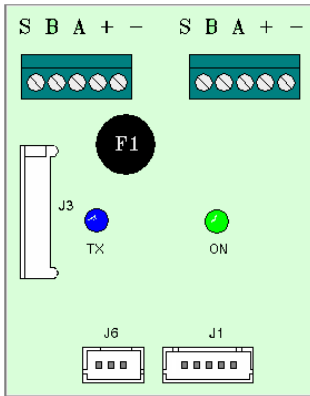

Terminal pins	Signal	Description
1	(-)	Negative
2	+12÷24VDC	Power supply
3	A	A RS-485
4	B	B RS-485
5	Screen	Cable Screen
LED Indications		
ON	Green	Power on
Modbus	Blue	RS-485 communication status

**c) RS485 serial line and 3 relays / .. / AD / CCS**

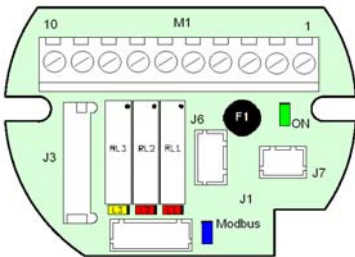

Terminal pins	Signal	Description
M1 Connector		
1	(-)	Negative
2	+12÷24VDC	Power supply
3	N/A	Not Used
4	NO/NC	First alarm threshold
5	Common	First alarm threshold
6	NO/NC	Second alarm threshold
7	Common	Second alarm threshold
8	NO/NC	Fault
9	Common	Fault
10	Screen	Cable Screen
Terminal pins	Signal	Description
J7 Connector	A	A RS-485
	B	B RS-485
LED Indications		
ON	Green	Power on
L1	Red	First alarm threshold
L2	Red	Second alarm threshold
L3	Yellow	Fault
Modbus	Blue	RS-485 communication status

**NOTE:**

All three relays are featuring one single contact only. Therefore while the relay is not activated the contact will remain open (N.O.) and LEDs will be OFF.

With the relay energized the contact will be closed and its related LED will be ON. So, should the relays be programmed as normally energized, the related contacts will be closed in normal operation and relative LED will be ON, and they will open when the associated event occurs (Alarm, Fault) or in case of main power interruption and related LED will automatically switch OFF.

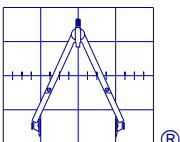

Relays alarm thresholds are programmed during production by the manufacturer on customer request and can be modified only by connecting the gas detector to a PC using a specific software called “enoseBlu2” (see enoseBlu2 software Instruction Manual for relays alarm thresholds modification procedure).

**d) Remote display configuration (not available for DUST/AD/.../ID version)**

If necessary, it is possible to add a DY-28 remote display to the gas detector. In this case the connections between the gas detector and the display unit shall be done as indicated in the picture.

The power electrical connections and the 4-20mA signal between the two units shall be done through the gas detector’s M1 terminal and the J1 connector of the DY-28 display unit.

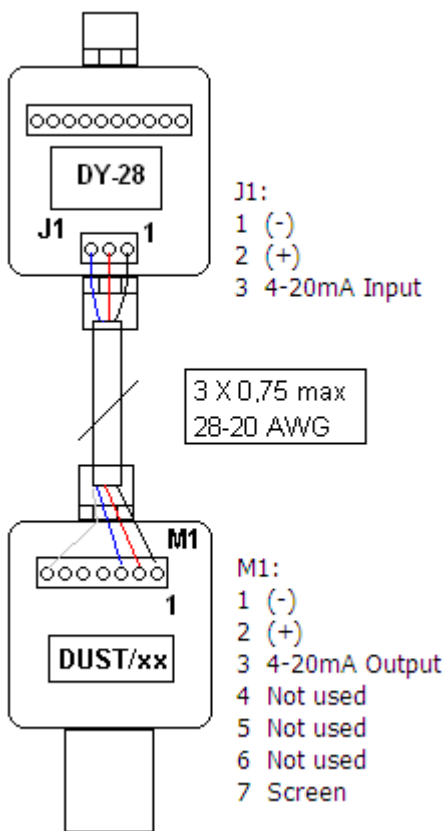

Pin J1 DY-28 display unit pin J1 assignment:

Terminal pins	Signal	Description
J1 Connector		
1	(-)	Negative
2	+12÷24VDC	Power supply
3	4-20mA	Analogue Output

For further information please see the DY-28 manual

**N.B.:** The remote display can only be connected with an AAS detectors main board, as the 4-20mA output is requested on the main board.

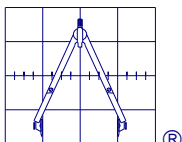

### 3.5 Final inspection and Start Up

Complete all cable insulation testing before connecting the cable at both ends.

The cable screen must be isolated and it must NOT BE CONNECTED TO THE ELECTRONIC CIRCUITRY OF THE SENSOR.

After all the wiring has been connected, the detector should be closed, sealed and eventually, the instrument may be powered on.

The device will warm up for 60 seconds, during which the 4-20mA output will be still at 2mA (Fault condition). In case of output relays version, during the warm up time the Fault relay will show the Fault condition and, when the warm up procedure will successfully finish, the Fault relay will return back to its normal position.

In case of gas detector Fault, the Fault relay will stay in Fault condition even after the warm up time has elapsed.

After the warm up procedure, in normal operation status, the instrument analogue output should be 4mA.

### 3.6 Fault conditions and Actions

Fault conditions are indicated by the detector by activation of fault relay (for CCS version) or giving 2mA on the analogue output signal (for AAS version).

The following table gives indication of fault conditions and possible actions:

Condition	Mode	Actions
Power up	Automatic reset	Wait for end of start-up cycle, about 1 minute
Start Up Fail	Latching	Switch the instrument OFF and ON again, if problem is not solved check sensor status and if necessary replace it
Sensor fault	Latching	Check sensor status and if necessary replace the sensor
EEPROM CRC Error	Latching	Restart the instrument, if problem is not solved send the instrument back to the supplier
Calibration Error	Latching	Try to make a new calibration, if problem is not solved replace the sensor
Over Range	Automatic reset	Check absence of gas in ambient, switch the instrument OFF and ON again, if problem is not solved check sensor status and if necessary replace it
Sensor negative drift	Automatic reset	Restart the instrument or make a new zero calibration

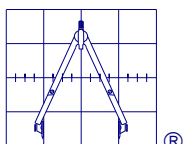

OGGIONI S.a.s. Via Laboratori Autobianchi, 1 20832 DESIO (MB) Italy  
 Tel. +39 0362 629135 Fax.+39 0362 622531 e-mail: [info@oggionisas.com](mailto:info@oggionisas.com)  
 On-line support [techsupport@oggionisas.com](mailto:techsupport@oggionisas.com) - web: [www.oggionisas.com](http://www.oggionisas.com)



Atex Certified



## **IV BUMP TEST**

The instrument is factory calibrated for one determined gas. It is recommended to check every three months the sensor response using a predetermined gas/air mixture. To make a correct BUMP TEST, follow the instructions below:

1. Mount the GM1 adapter on the sensor head and connect the flexible pipe to the regulator mounted on the gas cylinder.
2. Connect an ampermeter (with 20mA full scale) in series to the 4-20mA signal; on the ampermeter one shall read 4mA in normal conditions.
3. If gas detector has relays output only (CCS version), you can just check the relays being activated when over passing alarm thresholds while giving gas from the test gas bottle.
4. Slowly open the gas cylinder regulator until you have a flow not greater than 0,5 l/min. and maintain a constant flow of test gas.
5. The read current on ampermeter will increase until the maximum value is reached and the readout gets stable.
6. This step takes about 1min so the readout gets eventually stable, check the 4-20mA output with an ampermeter during the procedure.
7. If gas detector has relays output only (CCS version), you will see the relays activating when the read concentration reach the alarm threshold set for the relays activation (relays will change their status and you will see red LED switching ON or OFF according to the configuration requested – if normally energized or normally not energized).
8. After the test is finished close the gas flow and take off the GM1 adapter.

## **V CALIBRATION**

The instrument is factory calibrated for one determined gas. It is recommended to check every three months the sensor response using a predetermined gas/air mixture. To make a correct calibration, the following instruments are requested:

Calibration kit with adaptor for GM1 head.

Cylinder with test gas (preferably with a concentration at 50% of the instrument range).

Magnet for Calibration procedure.



*Before starting any verification procedure all personnel responsible for security must be informed and all alarm systems which might be connected to the system should be switched off.*

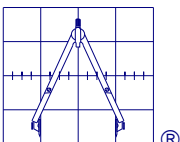

OGGIONI S.a.s. Via Lavoratori Autobianchi, 1 20832 DESIO (MB) Italy  
Tel. +39 0362 629135 Fax.+39 0362 622531 e-mail: [info@oggionisas.com](mailto:info@oggionisas.com)  
On-line support [techsupport@oggionisas.com](mailto:techsupport@oggionisas.com) - web: [www.oggionisas.com](http://www.oggionisas.com)



Atex Certified

### 5.1 ZERO Calibration



Fig. 1 Starting from this position, slowly move the magnet until reaching the final position in Fig. 2



Fig. 2 From this position remove the magnet and the zero calibration procedure is terminated

### 5.2 SPAN Calibration

To start the span calibration, mount the GM1 adapter to the sensor head and the gas cylinder via the rapid plug as in the picture.

Start the calibration procedure following the steps below. The span calibration can be done in two ways:

- blindly, see subchapter 5.2.1.
- checking the 4-20mA output with an ampermeter during the procedure (see subchapter 5.2.2.)



#### 5.2.1 Span calibration with relay outputs (CCS)

This procedure follows three steps :

Switch off all the alarm systems that might be connected to the gas detection system, informing all the security personnel and responsible.

Put the calibration magnet on the left side of the sensor, as shown in figure 1 and slowly move the magnet 120° to the right, as shown in figure 2, the PreAlarm red LED will switch on confirming the reading of the magnet, suddenly turn the magnet left (before the red LED switches off again) and put it back to the start position.

The PreAlarm red LED switches off, wait for about 40 seconds until the Alarm red LED switches on ( if after about 40 seconds the LED doesn't switch on the calibration procedure didn't start so repeat the sequence with the magnet)

Remove the magnet from the instrument head. In this moment the detector enters the span adjustment status.

Slowly open the adapter valve until you have a flow no greater than 0,5 l/min. and maintain a constant flow of test gas for about 60". Now the read value should be stable. After about 60 seconds close the adapter valve.

Wait for the red LED to switch off, in this moment the span calibration procedure is finished. If the Fault yellow LED changes its status (Fault condition) the calibration failed, so repeat all the procedure from the beginning. If the fault condition remain, please see par. 3.6

Remove the adapter from the gas detector's head and switch on again all the alarm systems connected to the gas detection system.

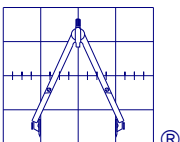

### 5.2.2 Span calibration using an ampermeter

Put the calibration magnet on the left side of the sensor, as shown in figures 1 and move the magnet 120° to the right, as shown in figure 2, wait 1 or 2 seconds and then bring the magnet in the start position to the left again.

Connect an ampermeter (with 20mA full scale) in series to the 4-20mA signal; on the ampermeter one shall read as follows:

Just after removing the magnet. The current will go down from 4mA to 1mA and will remain so for about 20s.

After the 20s, the expected calibration value will be shown, by default at 12mA, that corresponds to 50% of the full scale.

This value may be changed by the operator, should the calibration bottle concentration have a different value. See the NOTES below. Otherwise, should the gas bottle has the expected concentration, this value will be stable for about 20s.

After the 20s the detector will show the real gas value read so the ampermeter will read 4mA.

Slowly open the valve of the adaptor until you have a flow no greater than 0,5 l/min. and maintain a constant flow of test gas. The read current will increase until a maximum value is reached and the readout gets stable. This step takes about 1min so the readout gets eventually stable.

After about 1minute close the gas flow and take off the GM1 adapter. As soon as the gas read decreases below 80% of the highest value, the detector will set the span. The highest value read will be assigned to the expected span value. While doing this, the value in mA read on the ampermeter's display will drop to 1mA.

This step takes about 20s, then turning back to the real gas value in that moment. Considering the gas may be still inside the sensor head, the operator will probably read a current value dropping towards 4mA.

**!! WARNING!!** If the calibration fails, eventually the ampermeter will measure 2mA. In this case switch off the power, then power on again, wait for the detector to warm up and then repeat the calibration procedure.

Eventually, after the 4-20mA output gets stable to 4mA again (detector gets to zero again), it is recommended to check the calibration giving gas again from the bottle and checking the read value.

**NOTES** – Changing the expected calibration gas concentration:

To change the expected span concentration, as soon as the 12mA is read on the ampermeter, (see point b) above) attaching the magnetic tool to the head again (in central position) and keeping it still, the value of the expected concentration will start increasing. When the desired expected concentration value has been reached, the magnet should be removed.

If the desired value is lower than the default 50%, one should keep the magnet on until the full scale is reached, after which the counting will start over again from zero. Then, when the desired expected concentration value has been reached, the magnet should be removed.

A previous calculation is necessary, to find the current value corresponding to the gas bottle concentration, according to the detector range, making the following considerations:

The scale in current goes from 4mA corresponding to zero (fresh air in most of the cases except O2) to 20mA corresponding to the instrument full scale.

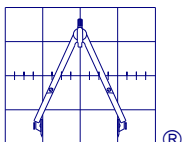

OGGIONI S.a.s. Via Lavoratori Autobianchi, 1 20832 DESIO (MB) Italy  
Tel. +39 0362 629135 Fax.+39 0362 622531 e-mail: [info@oggionisas.com](mailto:info@oggionisas.com)  
On-line support [techsupport@oggionisas.com](mailto:techsupport@oggionisas.com) - web: [www.oggionisas.com](http://www.oggionisas.com)



Atex Certified

Therefore there will be always a current trip of 16mA from zero to full scale value. The best thing to do is to calculate the gas bottle concentration equivalent in % of the full scale.

For the flammable gases with 100%LEL full scale for instance a 30% LEL concentration, will correspond to

$$4\text{mA} + 30\% * 16\text{mA} = 4\text{mA} + 4.8\text{mA} = 8.8\text{mA}.$$

For the toxic gases instead, having for instance a 300ppm full scale detector of CO and a gas bottle of 100ppm, the gas bottle concentration will be 33% of the range.

Therefore the calculation will lead to the following:

$$4\text{mA} + 33\% * 16\text{mA} = 4\text{mA} + 5.28\text{mA} = 9.28\text{mA}$$

### 5.2.3 Span calibration for Oxygen detectors using an ampermeter

- A) - Connect the oxygen cell to the electronic circuit (connection must be kept the same as the old one).
- B) - Wait for minimum 6 hours till the cell signal stabilizes. (if you cannot wait this time while installing the new cell, you can connect a 47 Ohm resistor between the two terminal pins of the oxygen cell the day before the installation, then when you are on the field and ready to install the new cell you can remove the resistor and proceed with the installation from point A).
- C) - Connect a tester (with 20mA full scale range) between pin 3 (4-20mA output) and pin 1 on the terminal block.
- D) - You should read 15,2 mA (corresponding to 20.9% Vol. Oxygen).

If you do not read the above value this means that the oxygen cell needs calibration, to calibrate it follow the procedure here below:

Apply 0% Vol. oxygen by a gas canister containing Nitrogen (N<sub>2</sub>) at 99.99% Vol. by using the detector head adaptor, wait till the values stabilize, then start calibration procedure as described before (Put the calibration magnet on the left side of the sensor, as shown in figures 1 and move the magnet 120° to the right, as shown in figure 2, wait 1 or 2 seconds and then bring the magnet in the start position again), follow the calibration start up on the multimeter, when you reach the time to give gas:

Close the gas canister valve, remove first the tubing from the adaptor then remove the adaptor from the detector head and wait till the values stabilize in clean air (20,9% Vol.) you should read 15,2 mA on the multimeter.

**NOTE:** Be sure to act this procedure in a clear air and not contaminated environment. Don't proceed with this procedure in a contaminated environment or in lack of oxygen.

It could be necessary to repeat points 1 and 2 more times to obtain the optimal calibration.

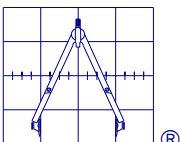
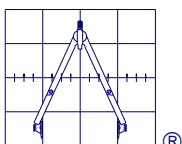

**Table 1 – Response time various sensors**

Gas	Formula	Sensor Technology	Standard Range	Response T <sub>50</sub>	Response T <sub>90</sub>
Flammable	HC	Standard Catalytic	0 - 100% LEL	n.a.	< 10 sec.
		High Qualità Catalytic	0 - 100% LEL	n.a.	< 10 sec.
		Infrared	0 - 100% LEL	n.a.	< 30 sec.
Various		MOS	Various	n.a.	< 10 sec.
Oxygen	O <sub>2</sub>	Electrochemical cell	0 - 30% Vol.	n.a.	< 15 sec.
Carbon Monoxide	CO	Electrochemical cell	0-300/500 ppm	< 10 sec.	< 30 sec.
			0-500/1500 ppm with H <sub>2</sub> and SO <sub>2</sub> filter	< 10 sec.	< 30 sec.
Carbon Dioxide	CO <sub>2</sub>	Infrared	0 - 10000 ppm	n.a.	< 30 sec.
			0 - 5% Vol.	n.a.	< 30 sec.
			0 - 100% Vol.	n.a.	< 30 sec.
Hydrogen	H <sub>2</sub>	Electrochemical cell	0 - 1% Vol.	n.a.	< 70 sec.
			0 - 4% Vol.	< 40 sec.	< 60 sec.
Ammonia	NH <sub>3</sub>	Electrochemical cell	0 - 100 ppm	< 20 sec.	< 60 sec.
			0 - 500 ppm	< 30 sec.	< 90 sec.
			0 - 1000 ppm	< 20 sec.	< 90 sec.
			0 - 5000 ppm	< 30 sec.	< 90 sec.
Hydrogen Cyanide	HCN	Electrochemical cell	0 - 30 ppm	< 25 sec.	< 50 sec.
Hydrogen Chloride	HCl	Electrochemical cell	0 - 30 ppm	< 30 sec.	< 70 sec.
Hydrogen Bromide	HBr	Electrochemical cell	0 - 30 ppm	< 30 sec.	< 70 sec.
Chlorine	Cl <sub>2</sub>	Electrochemical cell	0 - 10 ppm	< 30 sec.	< 60 sec.
			0 - 50 ppm	< 20 sec.	< 60 sec.
Hydrogen Sulfide	H <sub>2</sub> S	Electrochemical cell	0 - 30 ppm	< 15 sec.	< 30 sec.
			0 - 100 ppm	< 15 sec.	< 30 sec.
Sulphure Dioxide	SO <sub>2</sub>	Electrochemical cell	0 - 20 ppm	n.a.	< 35 sec.
Silane	SiH <sub>4</sub>	Electrochemical cell	0 - 50 ppm	< 10 sec.	< 60 sec.
Boron Trifluoride	BF <sub>3</sub>	Electrochemical cell	0 - 10 ppm	< 30 sec.	< 90 sec.
Hydrogen Fluoride	HF	Electrochemical cell	0 - 10 ppm	< 30 sec.	< 90 sec.



Ensure a complete understanding of all applicable State, Provincial and Local Health and Safety regulations before using these products.



OGGIONI S.p.A. Via Laboratori Autobianchi, 1 20832 DESIO (MB) Italy  
 Tel. +39 0362 629135 Fax.+39 0362 622531 e-mail: [info@oggionisas.com](mailto:info@oggionisas.com)  
 On-line support [techsupport@oggionisas.com](mailto:techsupport@oggionisas.com) - web: [www.oggionisas.com](http://www.oggionisas.com)



## VI MAINTENANCE

### Safety Warning



Installation and maintenance must be carried out by suitably skilled and competent personnel only.

Before starting any maintenance procedures, all responsible security personnel should be informed and all alarm systems which might be connected to the system should be switched off.

If correctly installed, the instruments need a routine maintenance, including the regular calibration. It is recommended that at least once a year a system check-up is being done that includes the following:

The sensor is calibrated in the factory specifically for the substance requested by the client. Nevertheless it is a good practice to check (possibly every three months) the sensor response in gas and recalibrate if necessary.

Make sure the atmosphere is clean and free of other gases before proceeding with the calibration and always use certified gas mixture bottles and never after the expiration date

The detector is provided with a sintered filter that during the operation may clog due to water, dust, oil etc. Check the filter by removing it and clean it with compressed air if necessary before refitting it.

**DO NOT USE COMPRESSED AIR ON FILTERS WHILE FIT ON THE DETECTOR HEAD!**

At the end of the maintenance inspection update the plant registers making sure to keep records of the action taken and the new calibration parameters.

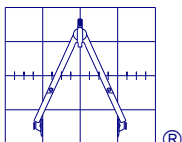

OGGIONI S.a.s. Via Laboratori Autobianchi, 1 20832 DESIO (MB) Italy  
Tel. +39 0362 629135 Fax.+39 0362 622531 e-mail: [info@oggionisas.com](mailto:info@oggionisas.com)  
On-line support [techsupport@oggionisas.com](mailto:techsupport@oggionisas.com) - web: [www.oggionisas.com](http://www.oggionisas.com)



Atex Certified

## **VII MODBUS RTU Serial Interface**

### **7.1 Introduction**

The Modbus communications interface is based on the two wire half-duplex RS485 standard in conformity to the EIA-485 specification.

The Transmitter implements the RTU protocol, the RTU mode and serial format must be the same for all devices connected on the network.

The Modbus interface factory default are set as follow:

Address        127  
 Baud rate     19k2  
 Parity        none  
 Stop Bit      1

### **7.2 Modbus read command**

- READ-MULTI-HR (cod. 03 dec. Read holding register)

### **7.3 Memory map**

(Holding Registers)

<b>REGISTER CATEGORY</b>	<b>MODBUS ADDRESS</b>	<b>NAME</b>	<b>UNIT</b>	<b>MEMORY</b>	<b>ACCESS LEVEL</b>
DIAGNOSTIC	12	Warning Quantity	General	E2PROM	READ ONLY
DIAGNOSTIC	13	Alarm Quantity	General	E2PROM	READ ONLY
DIAGNOSTIC	14	Maximum Gas	One Tenth of milliAmp	E2PROM	READ ONLY
DIAGNOSTIC	54	SIL Level	General	E2PROM	READ ONLY
DIAGNOSTIC	74	ResetHW Counter	General	E2PROM	ADMIN
READING FROM SENSOR	6	Percent Gas	Percentage	RAM	READ ONLY
READING FROM SENSOR	7	Sensor Output	milliVolt	RAM	READ ONLY
READING FROM SENSOR	9	Detected Gas Quantity	One Tenth of milliAmp	RAM	READ ONLY
READING FROM SENSOR	10	FBack Gas Quantity	One Tenth of milliAmp	RAM	READ ONLY
READING FROM SENSOR	11	Temperature	One Tenth of Centigrade	RAM	READ ONLY

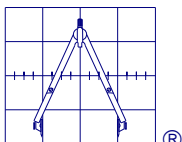

OGGIONI S.a.s. Via Lavoratori Autobianchi, 1 20832 DESIO (MB) Italy  
 Tel. +39 0362 629135 Fax.+39 0362 622531 e-mail: [info@oggionisas.com](mailto:info@oggionisas.com)  
 On-line support [techsupport@oggionisas.com](mailto:techsupport@oggionisas.com) - web: [www.oggionisas.com](http://www.oggionisas.com)





## **VIII ACCESSORIES**

Splash Guard

**Cod. GDA - SD**



Collector cone

**Cod. GDA - CO**



Sensor flow adaptor

**Cod. GDA – FA-1**



Portable calibration Kit

**Cod. GDA – TK**

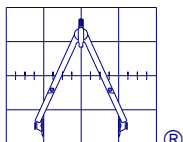

**OGGIONI S.a.s.** Via Lavoratori Autobianchi, 1 20832 DESIO (MB) Italy  
Tel. +39 0362 629135 Fax.+39 0362 622531 e-mail: [info@oggionisas.com](mailto:info@oggionisas.com)  
On-line support [techsupport@oggionisas.com](mailto:techsupport@oggionisas.com) - web: [www.oggionisas.com](http://www.oggionisas.com)



Atex Certified



# NOTE

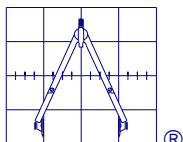

**OGGIONI S.a.s.** Via Lavoratori Autobianchi, 1 20832 DESIO (MB) Italy  
Tel. +39 0362 629135 Fax.+39 0362 622531 e-mail: [info@oggionisas.com](mailto:info@oggionisas.com)  
On-line support [techsupport@oggionisas.com](mailto:techsupport@oggionisas.com) - web: [www.oggionisas.com](http://www.oggionisas.com)



# NOTE

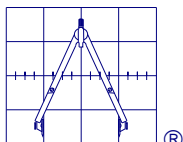

OGGIONI S.a.s. Via Lavoratori Autobianchi, 1 20832 DESIO (MB) Italy  
Tel. +39 0362 629135 Fax.+39 0362 622531 e-mail: [info@oggionisas.com](mailto:info@oggionisas.com)  
On-line support [techsupport@oggionisas.com](mailto:techsupport@oggionisas.com) - web: [www.oggionisas.com](http://www.oggionisas.com)



# NOTE

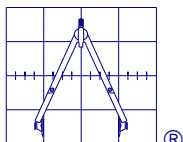

OGGIONI S.a.s. Via Lavoratori Autobianchi, 1 20832 DESIO (MB) Italy  
Tel. +39 0362 629135 Fax.+39 0362 622531 e-mail: [info@oggionisas.com](mailto:info@oggionisas.com)  
On-line support [techsupport@oggionisas.com](mailto:techsupport@oggionisas.com) - web: [www.oggionisas.com](http://www.oggionisas.com)



For more information please contact:

Oggioni s.a.s.  
DESIO (MB)  
Italy

Tel. + 39 0362 995062  
Fax. +39 0362 622531  
[www.oggionisas.com](http://www.oggionisas.com)  
[info@oggionisas.com](mailto:info@oggionisas.com)



The brochure includes general specifications which are subject to change without prior notice.

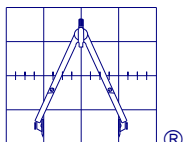

**OGGIONI S.a.s.** Via Lavoratori Autobianchi, 1 20832 DESIO (MB) Italy  
Tel. +39 0362 629135 Fax.+39 0362 622531 e-mail: [info@oggionisas.com](mailto:info@oggionisas.com)  
On-line support [techsupport@oggionisas.com](mailto:techsupport@oggionisas.com) - web: [www.oggionisas.com](http://www.oggionisas.com)



Atex Certified